

Alpha 900

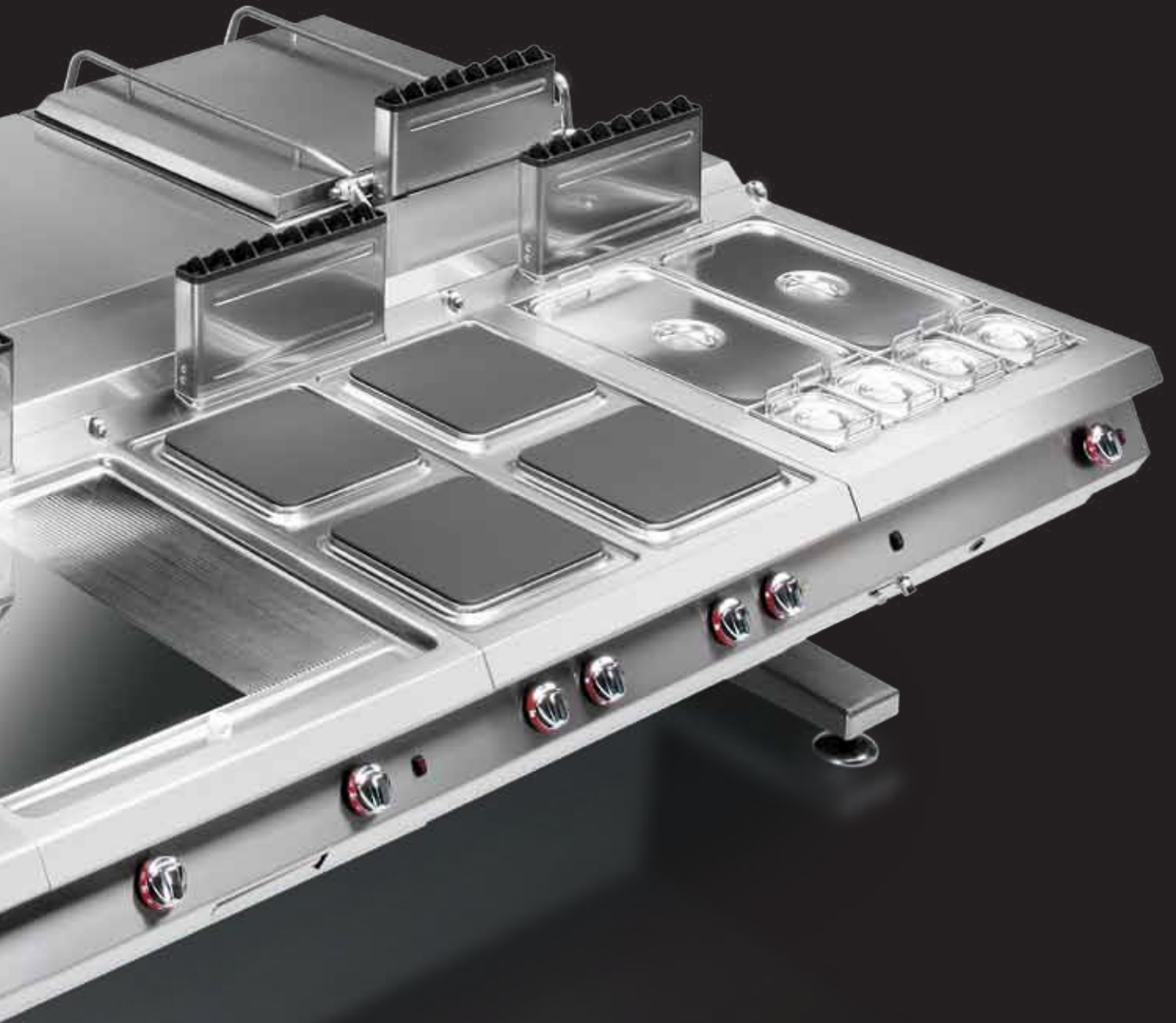

# ALPHA900 // MAKE THE DIFFERENCE





# ALPHA900 //

## // **HYGIENIC DESIGN**

Cleaning times and use of chemical products reduced by 20%

CSQA hygienic design certification.

Angelo Po cooking equipment is the **ONLY** type available on the market to have attained certification thanks to its design and construction features. It is easy to clean and sanitize.





# SUPERIOR PERFORMANCE

## // UNIQUE

The "covered" burners spark ignition provides the best service; guaranteeing IT IS EASY (just press a button) and SAFE for each single machine start operation.

## // VERSATILE

You can choose different compositions based on your needs (freestanding on feet, suspended on a beam or on multi-element stand). With over 150 models available we have the LARGEST equipment choice in the professional market.

## // POWERFUL

The Angelo Po Engineering research centre, one of the most advanced in the sector, designed our characteristic triple flame burner. Allowing maximum EFFICIENCY and UNIFORM heat to be transmitted to the cooking surface.

## // INTELLIGENT

Power is dependant on the electronic or thermostat control, ALWAYS present on cooking equipment.

## // DESIGNED FOR YOU

The largest and most performing range on the market for contact cooking (cast iron, soft steel, chrome and compound) RECOMMENDED based on type of menu offered.

# ALPHA900 //

## HOSPITALITY Catering

EQUIPPED FOR MAXIMUM  
COMFORT

### PASTA COOKER

A pressure gauge water  
recognition level system  
to avoid it running dry.



Automatic basket  
lift system for 40 litre  
pasta cooker.

Electronic spark  
ignition.

Stainless steel  
bordering plinth.

## GRIDDLES

Plate in compound:  
performance, cleanable  
and energy saving.

## CHARGRILL

Electric cast-iron grill with  
tank to contain water  
(contact system).



Technical element  
equipped with 3 single  
phase electric sockets  
(2 schuko and 1 tripolar).

Technical element  
equipped with retractable  
spray gun.

# ALPHA900 // MAKE THE DIFFERENCE

## // OPEN BURNERS

The sloped Venturi is patented for its innovative shape and to guarantee maximum combustion hygiene

KEEPING HARMFUL (CO<sub>2</sub>) EMISSIONS TO A MINIMUM.

Material used to make the burner, RAAF enamelled cast-iron, acts as a heat flywheel

IMPROVING BURNER YIELD BY 15%.





The double crown burner together with the flame's specific slope guarantees

## GREATER UNIFORMITY AND DISTRIBUTION OF HEAT

on the bottom of all sized pots.

Thus stopping heat accumulation in a single point and optimising the energy transferred to the product.

## ENERGY SAVING

(In the photo: thermal distribution measurement)

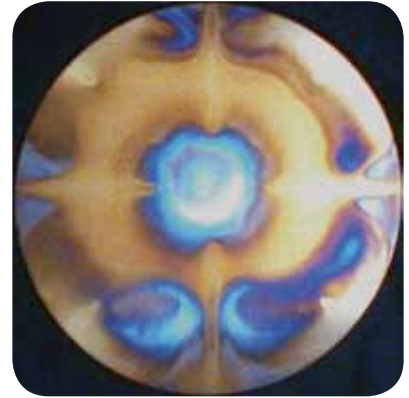

## // OPEN BURNERS

### USE

All types of pan cooking (bratt, boiled, roast meats, etc.).

### PERFORMANCE

- Power 10 and 7 kW with DOUBLE CROWN burners, 130 and 110 mm in diameter, and 4 kW single crown, for maximum heat distribution, exchange efficiency and uniformity.
- Burner pilot light (instead of spark), protected against accidental knocks and risen to protect the system from contact with liquids.
- Cast-iron grills designed to direct the flame and relative heat path onto the pan bottom.
- Under-counter oven with fully stainless steel chamber and ELECTRONIC SPARK BURNER IGNITION. Oven door closure obtained by pressing.

### EASE OF CLEANING

- Sloped Venturi, PATENTED, to protect the nozzle from getting blocked by liquids and fats.
- Hygienic design pressed counter tray with rounded corners.
- Under-knob protection against water infiltration.
- Cast-iron burners and pan grids easily removable and machine washable.

# // SOLID TOP RANGE

## USE

Indirect heat (on pan) to cook different foods, sauces and stews thanks to the differentiated isothermal zones (from 500° to 250°C).

## PERFORMANCE

- 16 Mo.5 steel plate with satin finish, oxidation resisting and ideal for heat exchange, heated by a central 12 kW gas BURNER. Thanks to its radiating ribs, the plate generates different isothermal zones degrading from centre (500°C) towards edges (250°C).
- Use of innovative active thermostatic controls SAVES energy thus decreasing heat in the working environment.
- Maximum temperature UNIFORMITY and heat maintenance thanks to the 15 mm thick plate.

## EASE OF CLEANING

- Wide hygienic design radius over the entire perimeter makes it really easy to clean equipment after use.

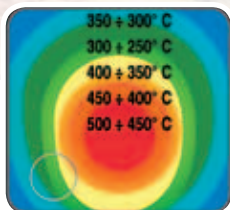

Temperature detection for gas model.

## // ELECTRIC SOLID TOP RANGE

Innovative control system for electric models enabling you to work with three different powers (K-Tronic) safeguarding operating costs.

10 TO 30% SAVINGS ON ENERGY COSTS

# // INDUCTION

## USE

For cooking in suitable induction pans or those with a stainless steel bottom. No pots with aluminium, glass or earthenware bottoms can be used.

## PERFORMANCE

- The induction cooking surface works on electricity: an inductor generates a magnetic field which sets the pots metal molecules in motion. The energy produced is transmitted to the pots with 10 possible regulation levels and cooks their content.
- 5 or 7 kW full heating zone models available. RAPID RESPONSE is guaranteed by power delivered based on cooking recipient.
- Environmental heat radiation is VERY LOW as all power is delivered to the pot bottom so there is no danger of getting burnt/scalded when coming into contact with the top which remains cold.
- Heat stops when the pan is removed.

## EASE OF CLEANING

Extremely easy to clean thanks to a smooth, hermetic glass ceramic top.

	Electric plates	Induction
Daily energy needs	152.1 kW/h	25.1 kW/h
	Savings	Earnings (Euro)
a day	127 kW/h	8,89
a month (30 days)	3810 kW/h	266,70
a year (365 days)	45720 kW/h	<b>3200,40</b>

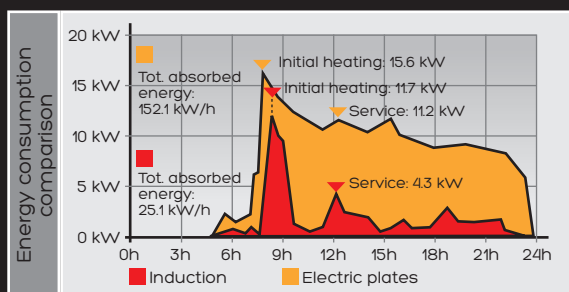

**ENERGY SAVINGS:**  
from 50% to 80% compared to traditional electric plates.



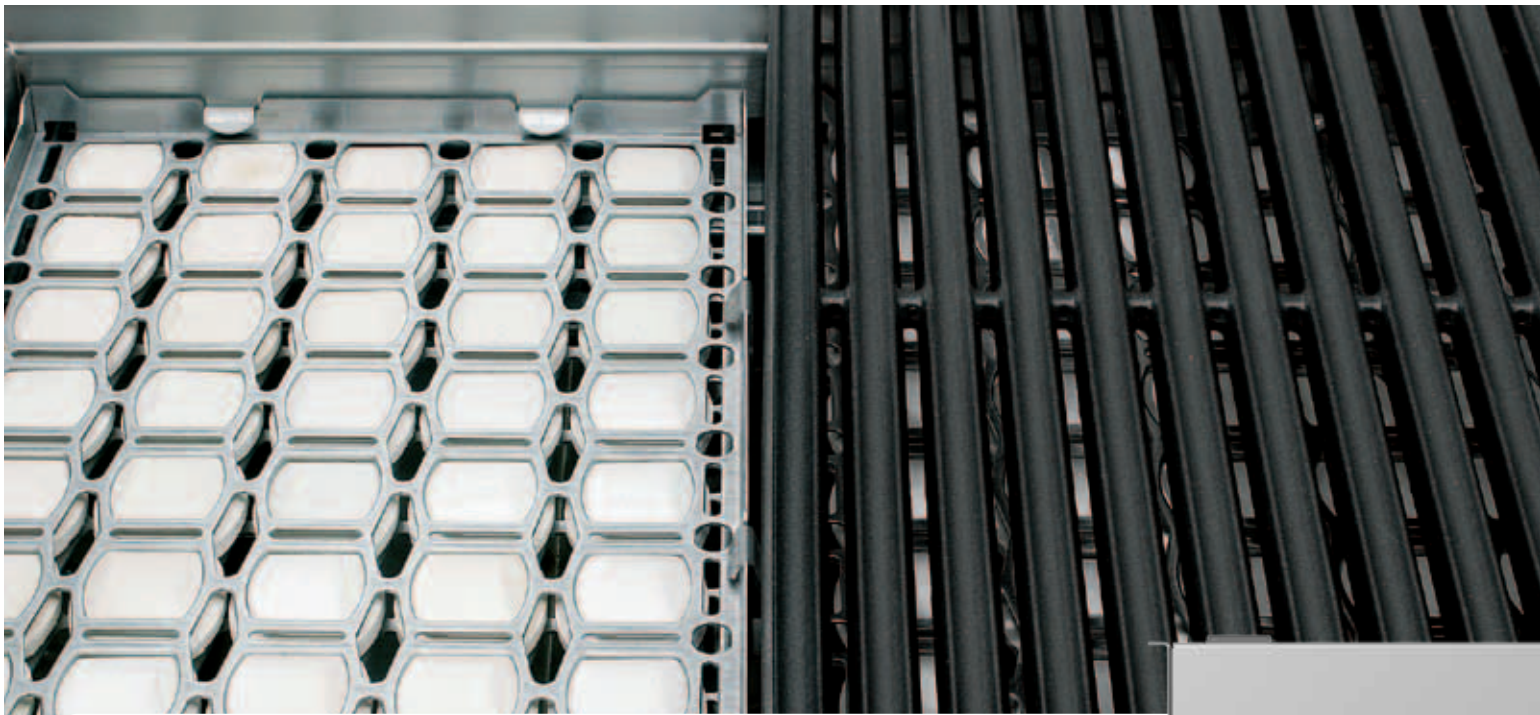

## // ELECTRIC MODELS

Thanks to the innovative contact system the consumption is reduced to just 11 kW of installed power (20% less than what competitors offer).



## // GRILL

### USE

Cooking through contact on cast-iron grid for meat, vegetable and fish.

### PERFORMANCE

- The ceramic stone GAS grid operates by heating the stone tiles inside the stainless steel supports with a 9 kW three flame burner. The cast-iron grid is placed over them. Food is cooked through RADIATION and CONTACT, increasing productivity with the same amount of energy used.
- ELECTRIC model: cooking grids are placed on the heating elements, guaranteeing reduced times to reach correct temperature. The CONTACT system guarantees excellent heat transfer from heating element to grid with no useless energy wasted.
- The electric grid operates with WATER under the counter to decrease smoking emissions and collect fat.

### EASE OF CLEANING/HYGIENE

- The grid can be reclined to help drain fats which flow into the drawer underneath.
- The parts to be washed: grid, tiles and burner can be removed completely without any tools. The heating element group can be raised to clean the underlying tank thoroughly.



## // PASTA COOKER

### USE

The pasta cooker can be used to cook pasta, rice and boiled vegetables (using Gastronorm containers h = 65/100 mm), eggs, etc...

### PERFORMANCE

- Pressed cooking well, in AISI 316L stainless steel, 15/10 mm thick, for lasting non deformability.
- Electronic spark ignition on pilot flame, high performance guaranteed by a combustion chamber under and around the well, up to minimum water level.

Power output per liter is 15% higher than competitors average.

- Automatic pressure gauge, stop at maximum level and top-up at minimum to avoid any "dry" operations when the machine is unmanned.

### EASE OF CLEANING

Counter top with expansion hollow equipped with raised hygienic edge h > 4 mm recommended by UNI-EN 1672-2.

# ALPHA900 // MAKE THE DIFFERENCE



## // ENERGY SAVING GRIDDLES

Use of multi-element combustion systems MCE (three flame burners),

guarantees better heat distribution on cooking surface. The MCE system guarantees correct heat uniformity and use of the entire available cooking surface.

Specific power distribution is  $W/dm^2 > 13\%$

# // GRIDDLE

## USE

Designed to grill different types of food without absorbing any liquid (thanks to the material) and without mixing tastes.

Depending on food types we recommend the following materials:

1 - COMPOUND 15 mm FE510D + AISI 316L (max temperature for the electric model 270°C, for the gas model 340°C) for meat, fish and vegetables. Characteristics: good heat exchange, low environmental emissions and long-lasting brightness of plate surface.

2 - SOFT STEEL FE510D (max temperature for the electric model 270°C, for the gas model 340°C) for meat and vegetables. Characteristics: excellent heat exchange and fast cooking.

3 - CHROME (max temperature for the electric model 280°C, for the gas model 270°C) for fish, cheese and eggs. Characteristics: maintains/spreads heat at plate level and long-lasting brightness of plate surface.

## PERFORMANCE

- Liquid-tight RECESSED cooking plate, suitable for immersed cooking.
- Maximum temperature UNIFORMITY on plate depending on equal distribution of power on useful surface. Thanks to the three flame burners, designed internally, and thermostatic power control (heat control sensors under plate).
- Maximum power thanks to W/Dm<sup>2</sup> YIELD 13% higher than competitor average.
- Burner ignition through ELECTRONIC spark ignition.

## EASE OF CLEANING

- PRESSED, PATENTED hygienic design counter top, with hole to collect and drain liquids.
- Discharge into gastronorm containers under counter or sent to fixed network drainage.

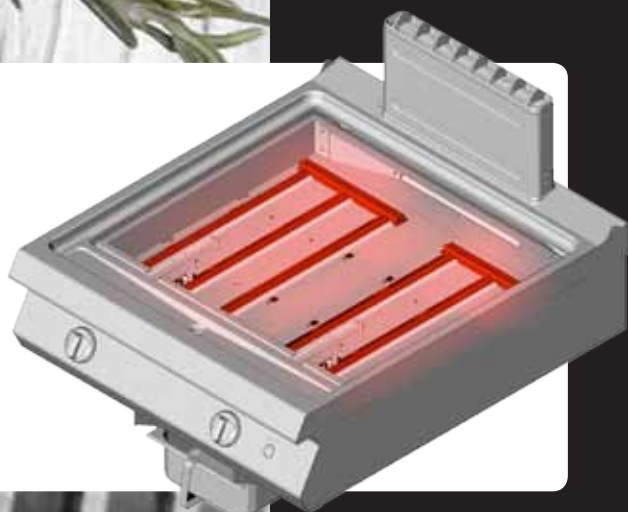

# ALPHA900 //

CONFIGURATIONS  
HOSPITALITY  
CATERING



40 x 90 x 24 h cm



80 x 90 x 24 h cm



120 x 90 x 24 h cm



OPEN BURNERS

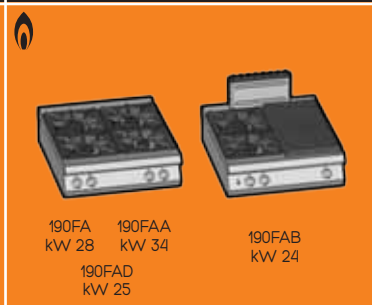

SOLID TOP RANGE

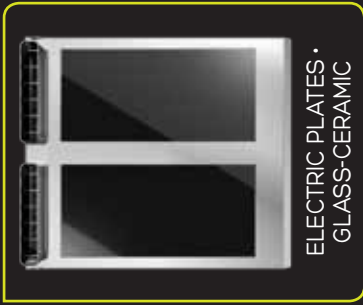
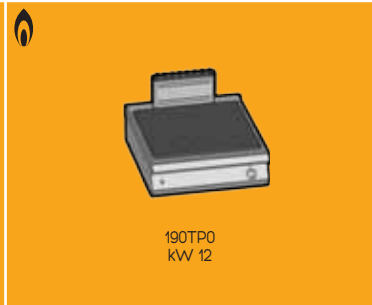

ELECTRIC PLATES •  
GLASS-CERAMIC

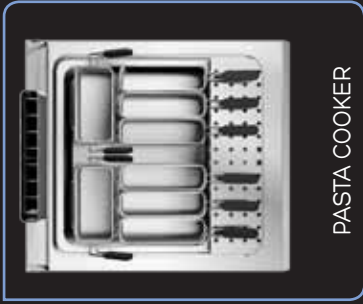
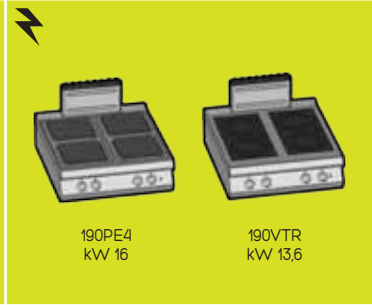

PASTA COOKER

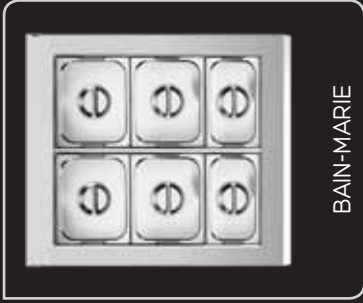

BAIN-MARIE

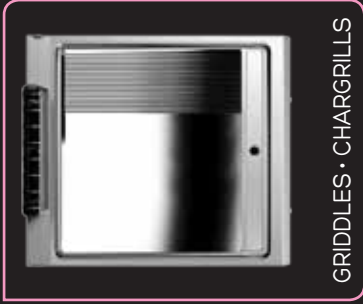
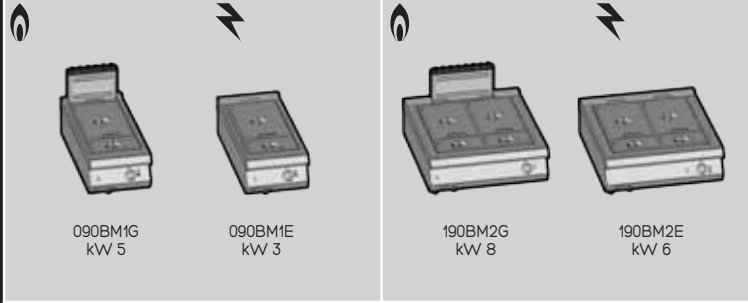

GRIDDLES • CHARGRILLS

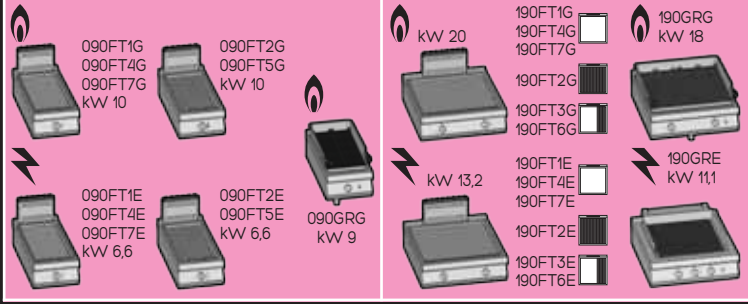





40 x 90 x 72 h cm



80 x 90 x 72 h cm



120 x 90 x 72 h cm



160 x 90 x 72 h cm

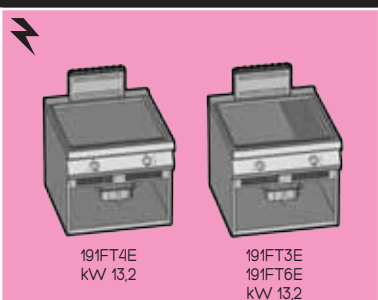
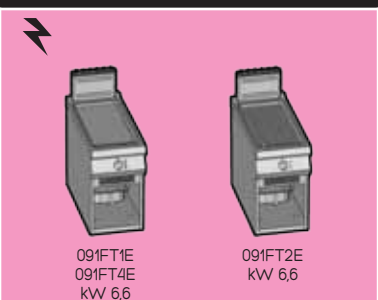
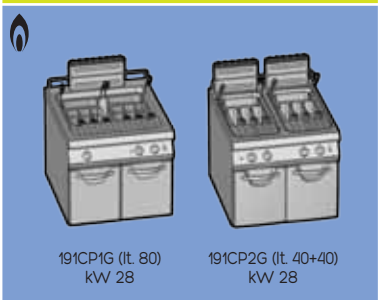
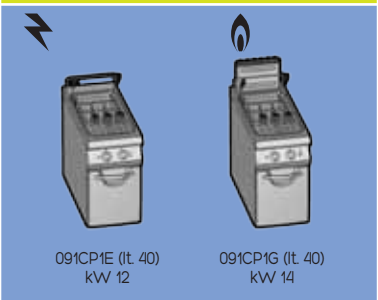
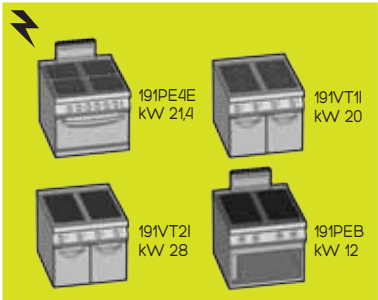
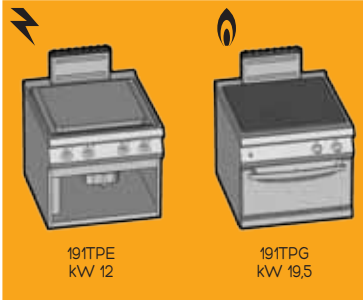
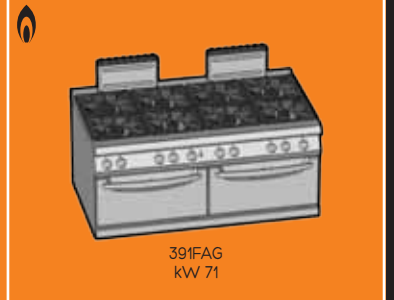
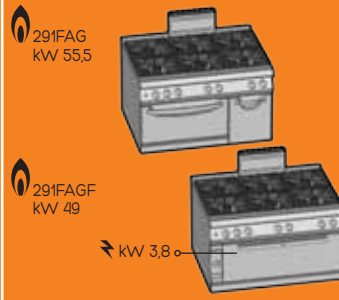
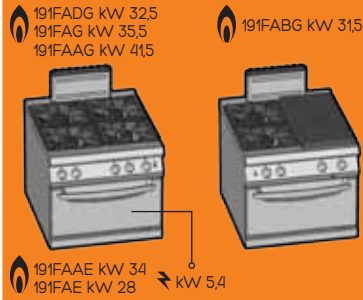

# ALPHA900 //

## PUBLIC SECTOR Catering

MAXIMUM PERFORMANCE

MULTICOOKER

Automatic cooking  
(programming times,  
temperature, water).

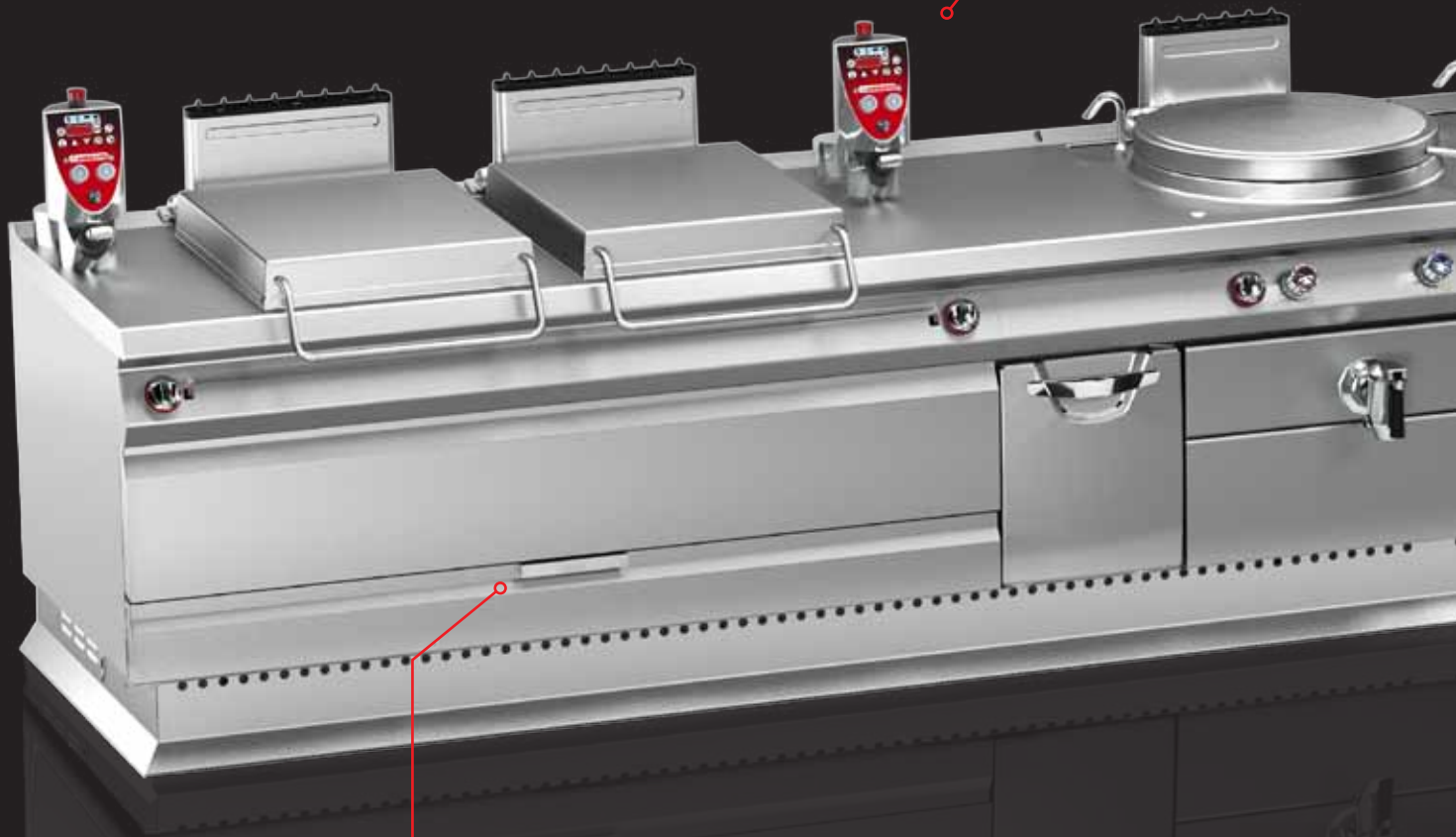

Front access to all  
"covered" burners for  
ordinary maintenance.

## BRATT PANS

Power modulation system.

## FRYER

Flame ionization ignition - by turning the knob/pressing the button the burner comes on automatically.

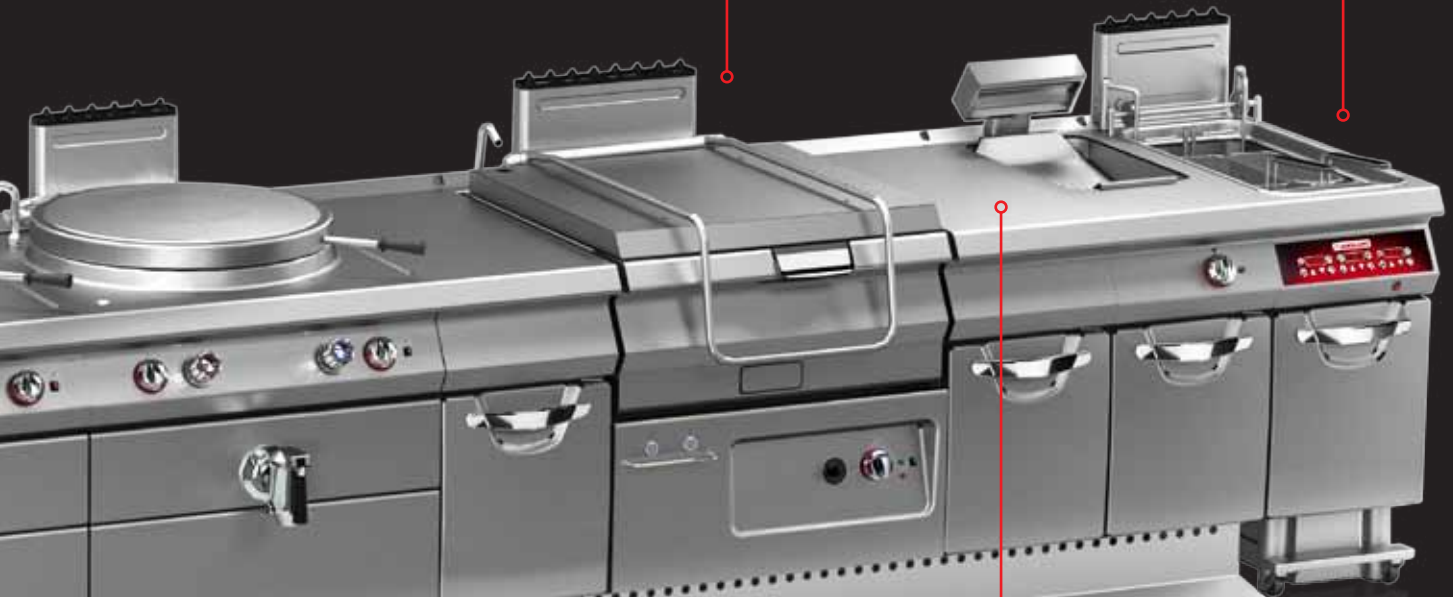

Gas burners with up to 70% yield (10% higher than competitors).

Frying system (automatic raising and oil filtering) with temperature maintenance module.

# // FRYER

## USE

Slow frying, from 130 to 140°C, for raw vegetables, fish and meat. Surface frying at 150°C for breaded items (vegetables and fish). Instant frying at 190°C to form an outer crust for potatoes.

## PERFORMANCE

- Gas models with heat exchange pipes in well or with special shaped well (burners outside tank) and electric models available.
- Direct gas burner ignition electronically controlled by atmospheric ionization (models "...1" and "...2" or electronic spark ignition (models "...1G" and "...2G").
- Simple, just turn the knob, effective and ENERGY SAVING. W/I yield 18% higher than main competitors.
- Productivity up to 45 Kg potatoes/h (AGA test) thanks to 1105 W/I power.
- Electronic control pcb to manage frying programs, HACCP alarms, melting and oil filtering.
- Programmable models with automatic basket lift system available.

## EASY TO CLEAN/HYGIENE

- Fully pressed well, without burners (special V shaped well).
- Automatic oil filtering and recycling system directly in the well by fully controllable switch. Safe discharge of oil outside the under compartment through an extension pipe. Discharge facilitates filtering to stop oil deterioration.

## // ENERGY SAVING FRYERS

Ionisation flame ignition system together with precise thermostatic control ensures that the device only works when really needed (reducing wasted energy and optimising the cooking process).

The introduction of an ionising system, used in modern high yield condensation boilers, replaces the pilot light group guaranteeing energy savings of up to 600 kW a year. Annual savings with reduced consumption of 60 m<sup>3</sup> of gas.

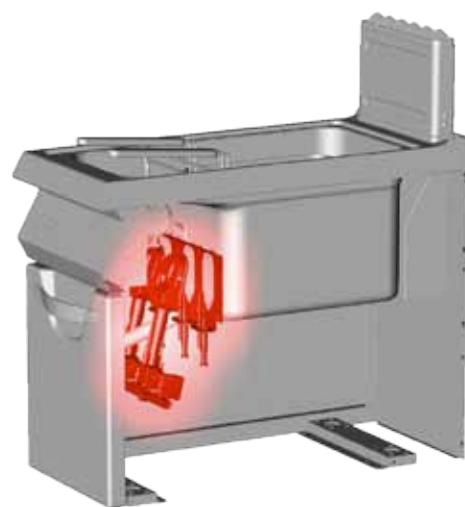



Specially shaped well.



Well with heat exchange pipes.



Heating elements tipped vertically by the electric model.

MODEL	POTATO CHIP PRODUCTIVITY*
091FR3G	11 kg/h
091FR3GD	13 kg/h
091FR3E	13 kg/h
091FR3ED	15 kg/h
191FR4G	22 kg/h
191FR4GD	26 kg/h
191FR4E	26 kg/h
091FR1I/091FR1G	26 kg/h
191FR4ED	30 kg/h
091FR7G	30 kg/h
091FR1D	31 kg/h
091FR1E	34 kg/h
091FR1IA	35 kg/h
091FR7GD	35 kg/h
091FR7GX	35 kg/h
091FR1ED	36 kg/h
091FR1EA	40 kg/h
091FR1EX	40 kg/h
191FR2I/191FR2G	52 kg/h
191FR2ID	62 kg/h
191FR2E	68 kg/h
191FR2ED	72 kg/h

\* based on AGA standard

# ALPHA900 // MAKE THE DIFFERENCE

## // ENERGY SAVING MULTICOOKER

Thanks to the innovative insulation system with thermal passive solutions, we can save up to 15% compared to similar machines present on the market.

Tests show that after 15 hours, with the machine off and lid lowered, the pasta cooker water only drops 14 degrees in temperature! Using this water again has evident advantages for

**energy and used water savings**  
(up to 450 litres of water per day).



# // MULTICOOKER

## USE

Very efficient cooker for pasta, rice, vegetables and low temperature cooking (meat and fish). Ideal for central kitchens, food industries and meat and fish production.

## PERFORMANCE

- AUTOMATIC cooking (with basket tilting when cooking is complete) setting different temperatures.
- Ignition and flame control through ionization for gas models.
- LOW TEMPERATURE COOKING from 60 to 65°C possible for meat and fish, with resulting reduced drop in weight and higher gastronomic quality than cooking made to order.
- It is possible to control the cooking process through a single point temperature core probe (special kit on demand).
- Memorised programs to allow you to program up to 5 different cooking cycles.
- Thanks to the combustion chamber developed in our laboratories, gas burner YIELD is 70% (competitors reach maximum 60%).
- Well WATER LEVELS are regulated by a three electrode system operating by conduction. In this way machine operations are completely efficient and safe.

## EASE OF CLEANING

Upper panel and instrument panel made in a SINGLE PIECE to eliminate the problem of the liquid overflowing from the counter into the machine.

Cleanability is guaranteed by its hygienic design, by the fully extractable single basket, by an isolated double panelled lid, by automatic water top-up during cooking thus reducing foam and stopping any overflowing.

## MULTICOOKER... WHAT KIND OF COOKING

Quantities obtained with automatic cooking at <85°C

	150 litres	200 litres
Vegetables	20 Kg	30 Kg
Meat	30 Kg	45 Kg
Fish	30 Kg	45 Kg

Quantities obtained with 4 successive cooking cycles at 100°C

	150 litres	200 litres
Large pasta	50 Kg	70 Kg
Spaghetti	40 kg	60 kg
Rice	60 kg	80 kg

NB Quantities given can vary depending on food types and relative cooking times.

# // BOILING PAN

## USE

Suitable for all kinds of immersion cooking. The DIRECT heating model is recommended for gravy, bouillon, soups and broth. The INDIRECT heating model (water jacket) is indicated for jams, sauces and products that do not need to be stirred all the time.

## PERFORMANCE

- The cooking tank is 15/10 mm thick with a 20/10 mm thick AISI 316L stainless steel bottom, to PROTECT it against oxidation caused by intense use with water and salt.
- Heating by 2 independent tubular stainless steel burner groups, with safety valve, pilot light and thermocouple.
- Electronic spark ignition.

## EASE OF CLEANING

Worktop incorporating the boiling pan, with continuous welding, condensation-collection edge and evacuation hole. Cylindrical cooking pan with polished bottom and RA 0.6 micron satin finish sides for easy cleaning.

Pan Operations

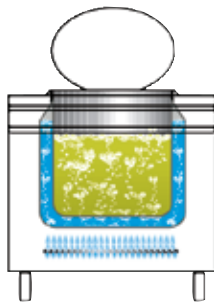

Indirect heating

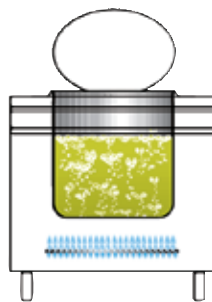

Direct heating





# // BRATT PAN

## USE

Multipurpose equipment suitable for cooking in the same well: creamed sauces, braised meats and all types of pan cooking.

## PERFORMANCE

- Cooking well in AISI 304 stainless steel for more delicate cooking needs.
- Thanks to two special six flame burners and a thick well bottom, for maximum temperature uniformity to guarantee homogenised cooking and considerable energy savings.
- Delivery of heating power controlled by power MODULATOR device, connected to double threshold level heat sensor, inserted directly in the well bottom.
- Electronic spark ignition of burners on pilot flame.

## EASE OF CLEANING

- Automatic or manual lifting and water input in well directly.
- CSQA Certification guaranteed by the cooking well's hygienic design rounded corners and by the discharge spout Angelo Po patent, to collect the cooked product easily.

The power modulation system allows us to rationalize delivery based on cooking needs, guaranteeing the right temperature with no excessive heat peaks.

Reducing energy waste by 20%, compared to traditional on/off systems, and allowing the user to cook in different modes (from made to order to long-lasting).

Power modulation Effect

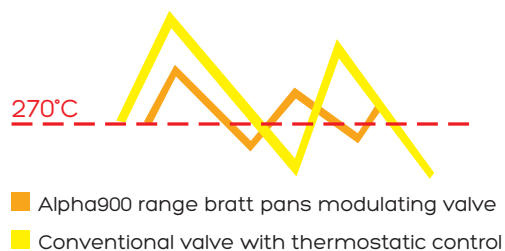

ALPHA900 // HD

MAKE THE DIFFERENCE



# // HD BOILING PAN

## USE

Automatic tilting boiling pans, indirect heating, with "U" structure for free-standing installation. Easy access to the components with separation between electric and water parts. Mainly suitable for cooking jams, creams, mashed potatoes, rice, soups and broths, which transfer takes place by tilting or unloading from the front tap.

## PERFORMANCE

- Bottom cooking tank made of AISI 316 stainless steel.
- Electronic board for automatic setting of:
  - time
  - temperature (with temperature probe)
  - 4 different cooking programs
- Sound system indicating temperature reached.
- Energy Saving system for power modulation.
- Safety thermic control with thermostat with reset, which operates in the case of water failure in the boiler.
- Water level control in cavity with automatic filling system.
- Automatic tilting through pressure sensitive button.
- Maximum strength and reliability to ensure continuous functioning (up to 24 hours a day).

## EASE OF CLEANING

- Moulded lid made of AISI 304 stainless steel with double-wall, with balanced monolithic hinges, with profile for condensation collection.
- Moulded and domed bottom tank with sloped drain for outflow of liquids.
- Joints between "HD" appliances for single surface, available.

## // HD BOILING PAN ENERGY SAVING

Every hour, after reaching set point, 40 minutes are FREE!

Thanks to the ON/OFF modulation system, when the machine reaches the set point, the maintaining consumption is only 6.8 kW/H against the standard consumption of 24 kW.

The efficiency is 30% higher than standard pans (from 20 to 90°C in just 30 minutes).



## // HD BRATT PAN

### USE

Automatic tilting bratt pans, direct heating, with "U" structure for free-standing installation. Suitable for boiling, browning, stir-frying, braising, frying in a thin layer of oil, contact cooking and steam in gastronorm perforated container.

### PERFORMANCE

- Bottom cooking tank made in COMPOUND, thickness 15 mm (3 mm of AISI 316 stainless steel and 12 mm of MILD STEEL).
- Electronic board for automatic setting of:
  - Time
  - Temperature
  - 4 different cooking programs
- Sound system indicating temperature reached.
- Energy Saving system for power modulation.
- Automatic tilting through unstable button (stop of the lifting/ lowering by removing finger pressure).
- Safety thermic control with electronic thermostat.
- Electronic spark ignition by GAS model.
- Maximum strength and reliability to ensure continuous functioning (up to 24 hours a day).

### EASE OF CLEANING

- Lid made of AISI 304 stainless steel with double-wall with diamond-tooling for directing condensation inside the cooking container; with balanced monolithic hinges.
- Moulded bottom tank to ease the cleaning and with sloped drain to direct the outflow of liquids.
- Joints between "HD" appliances for single surface, available.

### // HD BRATT PAN ENERGY SAVING

Thanks to the ON/OFF modulation system, when the machine reaches the set point, the maintaining consumption is reduced of the 60%.

The efficiency is 30% higher than standard bratt pans.

Time reduced by 25% for the first firing (40 minutes to get to temperature with the tank filled at the maximum level).





# ALPHA900 //

CONFIGURATIONS  
PUBLIC SECTOR  
CATERING

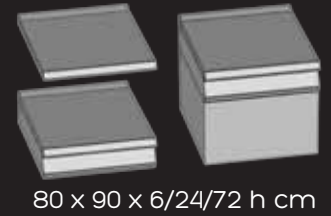
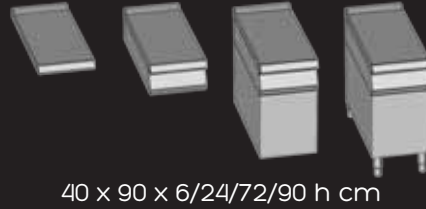

FRYERS

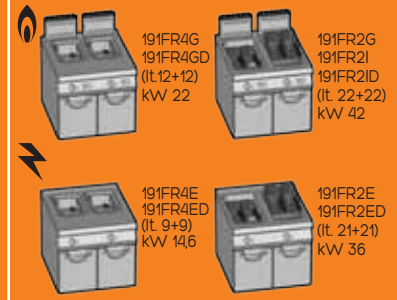
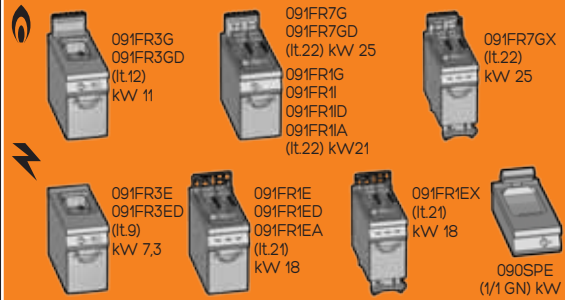

MULTICOOKER

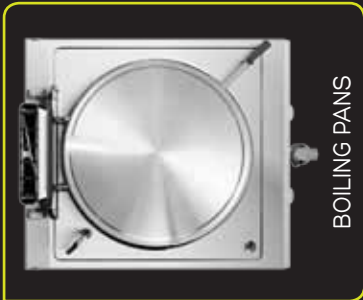

BOILING PANS



BRATT PANS

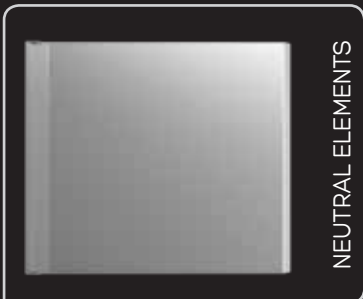
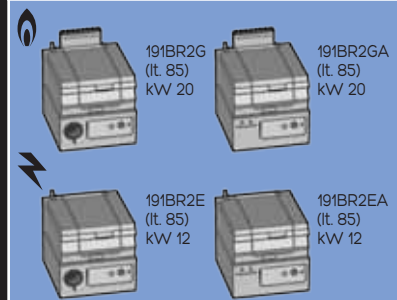
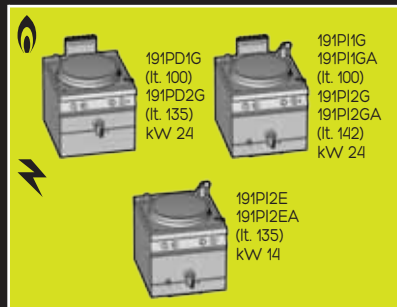

NEUTRAL ELEMENTS

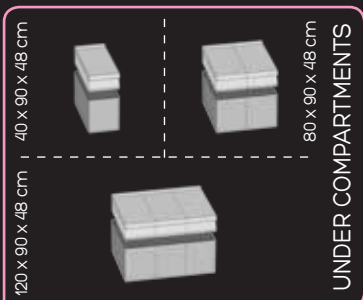
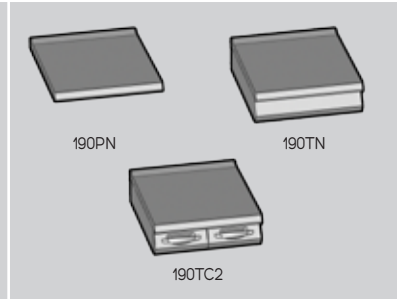
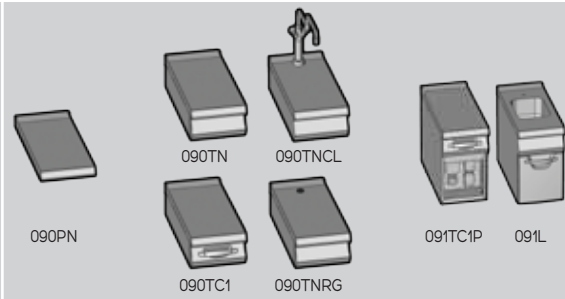

UNDER COMPARTMENTS

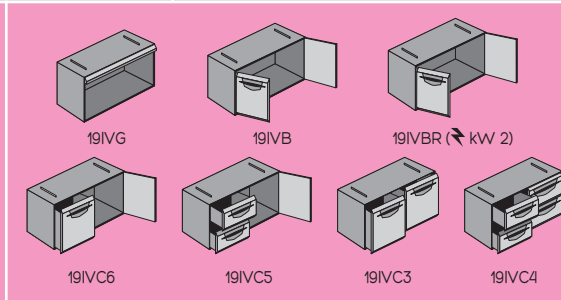
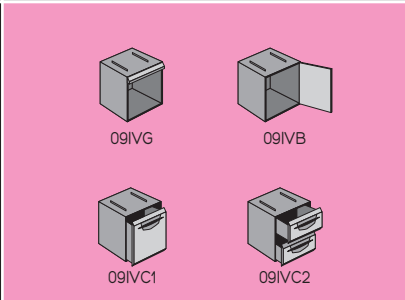



100 x 90 x 90 h cm

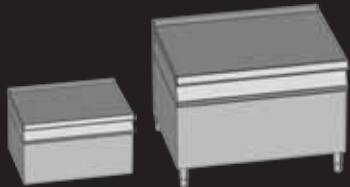

120 x 90 x 72/90 h cm



140 x 90 x 90 h cm

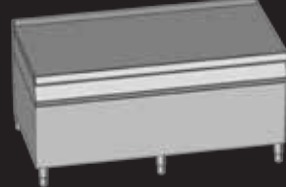

180 x 90 x 90 h cm

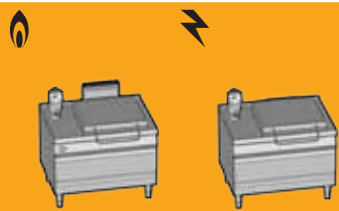

10CP1A  
(lt.150)  
kW 24

10CP1EA  
(lt.150)  
kW 18

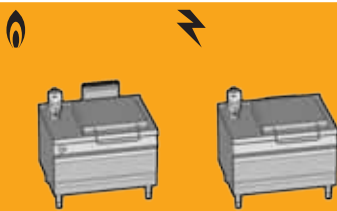

12CP1A  
(lt.200)  
kW 30

12CP1EA  
(lt.200)  
kW 18

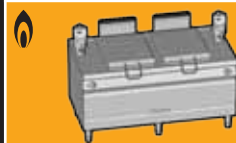

18CP2A  
(lt.150+150)  
kW 48

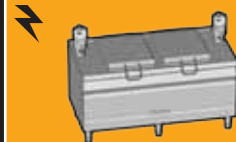

18CP2EA  
(lt.150+150)  
kW 36

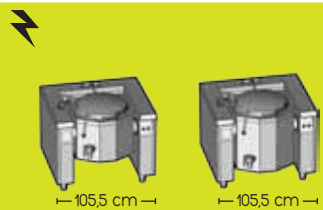

105,5 cm

105,5 cm

PIER06HD  
(lt. 60)  
kW 12

PIER10HD  
(lt. 100)  
kW 18



130,5 cm

PIER15HD  
(lt. 150)  
kW 24

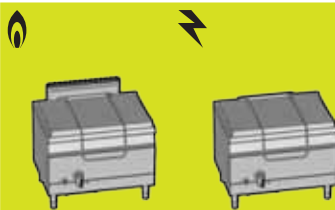

149PD3G - 149PI3G  
(lt. 270)  
kW 44

149PI3E  
(lt. 270)  
kW 32

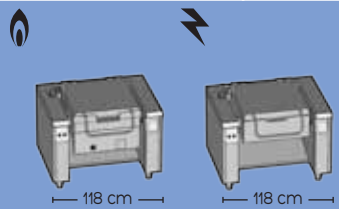

118 cm

118 cm

BRG21HD  
(lt.45)  
kW 12

BRE21HD  
(lt.45)  
kW 12

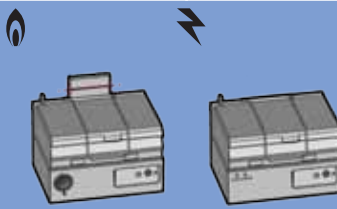

291BR2G/A  
(lt. 132)  
kW 30

291BR2E/A  
(lt. 132)  
kW 18

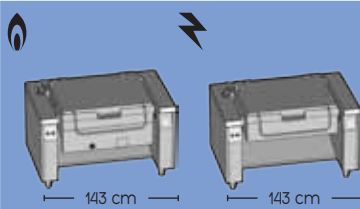

143 cm

143 cm

BRG31HD  
(lt.65)  
kW 15

BRE31HD  
(lt.65)  
kW 18

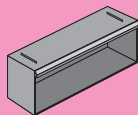

291VG

Angelo Po has been developing professional catering equipment for more than ninety years, coming up with solutions to take the grind out of kitchen work and create more efficiency. Cooking with profit, improved preservation and simplified preparation: these from the basis of the "Cooking System" guide lines devised by Angelo Po to provide quality, profitability and flexibility in all aspects of professional catering worldwide.

Angelo Po, with its company group and service network, is not only "The Ultimate Kitchen System" but, above all, "Global Service" is available for all the professionals who want to improve.



ANGELO PO Grandi Cucine SpA  
41012 CARPI (MO) - ITALY  
S/S Romana Sud, 90  
Tel. +39/059/639411  
Fax +39/059/642499  
www.angelopo.it  
angelopo@angelopo.it

7900445-3

