



Leggere attentamente le istruzioni prima di installare e utilizzare l'apparecchiatura.
Read the instructions carefully before installing and using the appliance.
Vor der Installation und Nutzung des Geräts müssen die Anleitungen aufmerksam durchgelesen werden.
Lire attentivement les instructions avant d'installer et d'utiliser l'appareil.
Léanse atentamente las instrucciones antes de instalar y utilizar el aparato.



Il mancato rispetto delle istruzioni fa decadere la garanzia del fabbricante.
In the event of failure to comply with the instructions, the manufacturer's warranty shall cease to apply. Die
Missachtung der Anleitungen hat den Verfall der vom Hersteller gewährten Garantie zur Folge.
Le non respect des instructions entraîne l'invalidation de la garantie du fabricant.
La inobservancia de las instrucciones provoca la invalidación de la garantía otorgada por el fabricante.

ABBATTITORI/SURGELATORI DI TEMPERATURA BLAST CHILLERS/FREEZERS SCHNELLKÜHLER/SCHOCKFROSTER CELLULES DE REFROIDISSEMENT RAPIDE/CELLULES MIXTES ABATIDORES/CONGELADORES RAPIDOS DE TEMPERATURA

ISTRUZIONI ORIGINALI - MANUALE D'USO E INSTALLAZIONE
ORIGINAL INSTRUCTIONS - USE AND INSTALLATION MANUAL
URSPRÜNGLICHE BEDIENUNGSANLEITUNG - BEDIEN- UND
INSTALLATIONSHANDBUCH

INSTRUCTIONS ORIGINALES - MANUEL D'UTILISATION ET D'INSTALLATION
INSTRUCCIONES ORIGINALES - MANUAL DE USO E INSTALACIÓN



Italiano **IT**

English **GB**

Deutsch **DE**

Français **FR**

Español **ES**



Rev.2 11/2025



3489330

INDEX

SAFETY WARNINGS AND INFORMATION	6
GENERAL INFORMATION	6
PERSONAL PROTECTIVE EQUIPMENT	7
GENERAL SAFETY	8
GENERAL SAFETY RULES	9
LOADING AND DISCHARGING OF FOODSTUFFS FROM THE MACHINE.....	12
CLEANING AND MAINTENANCE OF THE MACHINE.....	12
WARRANTY TERMS AND EXCLUSIONS	15
GENERAL INFORMATION	16
INTRODUCTION	16
ADDITIONAL INSTRUCTIONS	16
INTENDED USE AND RESTRICTIONS	16
EQUIPMENT IDENTIFICATION / NAMEPLATE DATA	16
TESTING.....	17
COPYRIGHTS.....	16
STORING THE MANUAL	16
INTENDED AUDIENCE OF THE MANUAL	16
DEFINITIONS.....	16
RESPONSIBILITY	17
LIST OF REGULATION REFERENCES	17
NORMAL USE OF THE MACHINE	18
CHARACTERISTICS OF PERSONNEL TRAINED IN ROUTINE USE OF THE MACHINE	18
CHARACTERISTICS OF PERSONNEL AUTHORISED TO WORK ON THE MACHINE.....	18
THE OPERATOR IN CHARGE OF ROUTINE USE	18
TRANSPORTATION AND HANDLING	18
UNPACKING.....	19
POSITIONING.....	19
DIMENSIONS	20
TECHNICAL DATA.....	23
ELECTRICAL CONNECTION.....	24
CONTROL AND SAFETY SYSTEMS	25
REFRIGERANT MATERIAL SAFETY DATA SHEET	25
DISPOSAL.....	26
OPERATION	27
SETTING UP	27
MACHINE LOADING.....	28
POSITION OF TRAYS.....	28
CORE PROBE	28
TEMPERATURES	29
LENGTH	29
CONTROL PANEL	30
PROGRAMME	32
PRE-COOLING CYCLE	33
CORE PROBE POSITIVE SOFT QUICK COOLING CYCLE	33
CORE PROBE POSITIVE HARD QUICK COOLING CYCLE	33
CORE PROBE NEGATIVE SOFT QUICK COOLING CYCLE	34
CORE PROBE NEGATIVE HARD QUICK COOLING CYCLE	34
TIME-CONTROLLED POSITIVE SOFT QUICK COOLING CYCLE.....	35
TIME-CONTROLLED POSITIVE HARD QUICK COOLING CYCLE.....	35
TIME-CONTROLLED NEGATIVE SOFT QUICK COOLING CYCLE.....	36
TIME-CONTROLLED NEGATIVE HARD QUICK COOLING CYCLE.....	36
DEFROSTING	37

CHANGING PARAMETERS	38
ALARMS AND FAULT ANALYSIS.....	39
SIGNALS.....	39
INDICATIONS.....	40
ALARMS.....	40
ERRORS.....	41
MAINTENANCE	42
ROUTINE MAINTENANCE.....	42
NEEDLE PROBE CLEANING.....	43
TRAY HOLDERS AND INNER STRUCTURE.....	43
DRAIN PLUG	43
OTHER SURFACES.....	44
CLEANING THE AIR CONDENSER	44
STAINLESS-STEEL MAINTENANCE.....	45
PRECAUTIONS IN THE CASE OF LONG PERIODS OF INACTIVITY	45
TROUBLESHOOTING	46
ANOMALY TABLES	46
EXTRAORDINARY MAINTENANCE	51
MAINTENANCE OF PANEL BOARD.....	51
CONDENSING SYSTEM MAINTENANCE	52
FURTHER INFORMATION	53
ERGONOMIC FEATURES	53
CERTIFICATION	53
GENERAL RECOMMENDATIONS.....	53
RECOMMENDED HANDLING OF TRAYS ACCORDING TO THEIR WEIGHT	54
ENERGY CONSUMPTION CHART (*)	55
WIRING DIAGRAM PLATE	56

Foreword

Read the following instructions, including the terms of warranty, before installing and using the machine.

The installation, operation and maintenance manual provides users with useful information for using the machine correctly and safely.

The instructions in this manual constitute a series of warnings whose purpose is to guarantee the performance of the machine and to prevent damage to persons, animals and property as a result of incorrect conditions of use.

It is important that all persons involved in the transport, installation, commissioning, use, maintenance, repair and decommissioning of the machine consult and read this manual carefully before proceeding with the various operations, in order to prevent incorrect manoeuvres and mishaps which could jeopardise the integrity of the machine or be hazardous to personal safety. The user should be regularly informed of safety regulations. It is also important to instruct and update the personnel authorised to operate the machine on its use and maintenance.

It is important that the manual always be kept at the disposal of operators and that it be carefully stored at the place of operation of the machine so that it can be easily and immediately accessible for consultation should doubts arise or if circumstances require it.

In the event of any doubts or uncertainties even after consulting the manual regarding use of the equipment, contact the Manufacturer or the Authorised service centre, which will be available to ensure prompt and accurate assistance for better operation and maximum efficiency of the machine. Bear in mind that the regulations in force on safety, hygiene at work and environmental protection must always be observed during operation of the machine. It is the user's responsibility to ensure that the machine is only operated and used under optimum safety conditions for people, animals and property.

IMPORTANT

The manufacturer disclaims all liability for any operation carried out on the equipment disregarding the instructions in this manual.

The manufacturer reserves the right to modify the characteristics of the equipment presented in this publication without prior notice.

Whole or partial reproduction of this manual is prohibited.

The manual is available in electronic format either by contacting the supplier or by contacting customer service or by downloading the latest version from the website.

The manual must always be kept near the machine in an easily accessible place. Operators responsible for use and maintenance of the machine must have it available for consultation at any time.

Annotate the emergency assistance number of specialised maintenance personnel.

Name and Surname	Address	Tel./fax no.

SAFETY WARNINGS AND INFORMATION

GENERAL INFORMATION

WARNING: This appliance contains hydrocarbon refrigerant (R290 or R600a).

DANGER: Risk of fire or explosion. Flammable refrigerant used. Do not use mechanical devices to defrost the appliance. Do not puncture refrigerant tubing.

DANGER: Risk of fire or explosion. Flammable refrigerant used. To be repaired only by trained service personnel. Do not puncture refrigerant tubing.

CAUTION: Risk of fire or explosion. Flammable refrigerant used. Consult repair manual/owner's guide before attempting to service this product. All safety precautions must be followed.

CAUTION: Risk of fire or explosion. Dispose of properly in accordance with federal or local regulations. Flammable refrigerant used.

CAUTION: Risk of fire or explosion due to puncture of refrigerant tubing; follow handling instructions carefully. Flammable refrigerant used.

CAUTION: Do not store explosive substances such as pressurized containers with flammable propellant inside the appliance.

CAUTION: Keep clear of obstruction all ventilation openings in the appliance enclosure or in the structure for building-in.

It is necessary to be familiar with the terms and conventions used in the manual in order to allow safe use and understanding of the machine.

Below is a list of symbols to identify the various types of warnings and dangers.



WARNING – Signal warning of flammability due to the presence of flammable refrigerant (R290 or R600a)



WARNING – Danger to the health and safety of persons involved



WARNING – Risk of electric shock – dangerous voltage



CAUTION – Danger of damage to machine or the product being processed



IMPORTANT – Important product information or instructions



Equipotentiality



Read instructions before using the equipment



Insights and explanations

This equipment is intended for use in commercial applications such as restaurant kitchens, canteens, hospitals, public institutions, bakeries, butcher shops, etc. It is not suitable for continuous large-scale food production.

The machine must be used by specialised personnel.

Under supervision or if instructed in safe use and understand the inherent risks, this equipment may be used by children over 8 years of age and by persons with limited physical, sensory or mental capabilities or lack of appropriate knowledge.

Do not allow children to play with the equipment.

Keep packaging materials and cleaning agents out of the reach of children.

Cleaning or maintenance work must not be carried out by children without supervision.

Do not store explosive substances such as pressurised containers with flammable propellant in this equipment.

Do not remove, tamper with or render the machine marking illegible.

Destroy the marking when scrapping the machine.

Keep these instructions carefully for reference by the various operators.

PERSONAL PROTECTIVE EQUIPMENT

Summary table of personal protective equipment (PPE) to be used during machine work.

Description	Protective clothing	Safety footwear	Gloves	Goggles	Helmet or hardhat
Transport	-	■	□		
Handling	-	■	□		
Packaging removal	-	■	□		

Installation	-	■	■ (1)		
Routine use	■	■	■ (2)		
Adjustments	□	■	-		
Routine cleaning	□	■	■ (1-3)		
Special cleaning	□	■	■ (1-3)		
Maintenance	□	■	□		
Dismantling	□	■	□		
Scrapping	□	■	□		
Key:					
■	PPE REQUIRED				
□	PPE AVAILABLE OR TO BE USED IF NECESSARY				
-	PPE NOT FORESEEN				

(tab 1)

1. Cut-resistant gloves must be worn during these operations. Please note that failure to use personal protective equipment by operators, specialised personnel or others involved in the use of the equipment may result in exposure to health hazards.
2. During this operation, gloves protect hands from cold or hot pans as they are removed from the equipment. Please note that failure to use personal protective equipment by operators, specialised personnel or others involved in the use of the equipment may result in exposure to chemical hazards and cause damage to health.
3. During these operations, gloves must be suitable for contact with the chemicals used (refer to the safety data sheet of the substances used for information on the PPE required). Please note that failure to use personal protective equipment by operators, specialised personnel or others involved in the use of the equipment may result in exposure to chemical hazards and cause possible damage to health.

GENERAL SAFETY

The machines are equipped with electrical and/or mechanical safety devices to protect workers and the machine itself.

Tampering with the machine or having it operate without guards or safety devices is strictly prohibited.

Do not make any modifications to the parts supplied with the equipment.

Please note that the parts of the manual illustrating parts without guards are used to facilitate understanding.

Using the machine without guards or with guards deactivated is prohibited.

Removing, modifying, tampering with or rendering the danger and obligation labels and safety signs on the machine illegible is prohibited.





GENERAL SAFETY RULES

Guards installed on the machine

Safety measures are represented on the machine by:

- Fixed guards (condenser guards, tops, side panels, etc.), fixed to the machine and/or frame with screws or quick-release couplings that can only be removed or opened with tools or instruments. The user is advised not to remove or tamper with these devices. The Manufacturer declines all liability deriving from tampering or non-use.
- Mobile interlocked guards (door) for access to the inside of the machine.
- Access doors to the machine's electrical equipment are made of panels that can be inspected only using tools. Do not open the door while the machine is connected to the power supply.

Safety signs to be displayed on or near the machine:

Prohibited	Meaning
	Do not remove safety devices
	Do not use water to extinguish fires
Danger	Meaning
	Caution: hot surface
	Caution: steam output
	Danger of electrocution (displayed on electrical components with indication of voltage)

(tab 2)

Discontinued use

- In case of prolonged non-use of the equipment, it is advisable to render it inoperative by disconnecting the power cable from the mains.

Warnings for use and maintenance

There are mainly mechanical, thermal and electrical hazards on the machine. Wherever possible, the risks have been neutralised:

- Directly by adopting suitable design solutions
- Indirectly by adopting protections and safety devices.

- By signalling any abnormal situations on the display on the door or instrument panel
- During maintenance, however, certain risks remain that cannot be eliminated and must be neutralised by adopting specific behaviour and precautions.
- Carrying out checks, cleaning, repair or maintenance operations on moving parts is prohibited. Operators must be informed of this prohibition by means of clearly visible notices.
- In order to guarantee the efficiency and correct operation of the machine, it is essential to carry out periodic maintenance following the instructions given in this manual.
- It is advisable to periodically check the correct operation of the safety devices and the insulation of the electrical cables. We recommend replacing them if they are damaged.
- Extraordinary maintenance operations on the machine must only be carried out by specialised personnel equipped with all suitable personal protective devices, equipment, tools and aids.
- Removing and/or operating the machine after removing, modifying or tampering with guards, protections or safety devices is always prohibited.
- The equipment is designed for a sound pressure level below 70db (A). 

Reasonably foreseeable misuse

Any use other than that specified in this manual is considered incorrect.

Other types of work or activities are not permitted during machine operation that are to be considered as misuse or that may generally lead to safety hazards for operators and damage to equipment. Reasonably foreseeable misuse is considered to be:

- Lack of maintenance, cleaning or periodic checks of the machine;
- Structural modifications or changes to the operating logic;
- Tampering with guards or safety devices;
- Non-use of personal protective equipment by operators, specialised personnel or maintenance staff;
- Failure to use suitable accessories (e.g. use of unsuitable equipment or ladders);
- Storage in the vicinity of the machine of combustible or inflammable materials or in any case materials that are not compatible with or not pertinent to work;
- Incorrect machine installation;
- Introduction of objects into the machine which are not compatible with its use or which may damage the machine, persons or pollute the environment;
- Boarding onto the machine;
- Failure to comply as described in the intended use of the machine;

- Other behaviour which causes risks that cannot be eliminated by the Manufacturer;

The behaviours described above are to be considered prohibited.

Residual risks

- The machine poses risks that it has not been possible to eliminate completely by design or through the installation of suitable protections. Operators have in any case been informed of these risks through this manual, which carefully states which personal protective equipment is present for employees. Sufficient space is provided during installation of the machine to limit these risks.

To preserve these conditions, the areas surrounding the machine must always:

- Be kept free of obstacles (such as ladders, tools, containers, boxes, etc.)
- Be clean and dry;
- Be properly lit.

The residual risks remaining on the machine are listed below for the user's complete information; such behaviour is to be considered incorrect and therefore strictly forbidden.

Residual risk	Description of dangerous situation
Slip or fall	Operators may slip due to the presence of water or dirt on the floor.
Burns/abrasion (e.g. heating elements, cold pan, cooling fins and pipes)	Operators intentionally or unintentionally touch certain components inside the machine without using protective gloves.
Electrocution	Contact with live electrical parts during maintenance operations carried out with the electrical panel live.
Fall from height	Operators work on the machine using unsuitable means of access to the top (e.g. ladders or climbing on top)
Tipping loads	Use of unsuitable attachments or lifting systems or unbalanced loading when handling the machine or the packaging containing the machine.
Chemical (refrigerant fluid)	Inhalation of refrigerant fluid. Therefore always refer to the labels on the equipment
Eye damage, skin damage	Ion exposure for equipment with ionising systems, if the door interlock fails

(tab 3)

Normal use of the machine

- If the equipment includes an ionising system, DO NOT inhale air in the vicinity of the source.
- Should an anomaly occur (short circuit, cables outside the terminal box, motor failure, damage to the cable protection sheaths), the operator must immediately switch off the machine by disconnecting the power supply.

LOADING AND DISCHARGING OF FOODSTUFFS FROM THE MACHINE

- Cover or wrap food before placing it in the machine.
- Wear kitchen gloves when loading and unloading food.
- Please observe the table below for the maximum load for each piece of equipment and shelf:

Model	Maximum blast-chilling load (kg)	Maximum shelf load (kg)
...51H (5LGN11)	15	40
...51DM (5LGN11)	18	40
...51-...51M (5LGN11)	20	40
...101L (10LGN11)	45	40
...141L (14LGN11)	70	40
...171L (17LGN11)	70	40
...51 (nr.6 36x16,5x12)	20	40
...101 (nr.12 36x16,5x12)	30	40
...171 (nr.18 36x16,5x12)	40	40
...102 (nr.40 36x16,5x12)	40	40

(tab 4)

CLEANING AND MAINTENANCE OF THE MACHINE

- Before any cleaning or maintenance operation, disconnect the equipment from the electrical mains.
- Do not touch the equipment if your hands and/or feet are wet or if barefoot.
- Do not remove safety guards.
- Use a ladder with a guard-rail when working on equipment with accessibility from above.
- Use suitable personal protective equipment.
- Maintenance and inspection work, as well as machine overhauls, must only be carried out by specialised personnel or by customer service equipped with suitable personal protective equipment, tools and aids.
- Work on electrical equipment may only be carried out by specialised personnel or by customer service.
- The machine must be set in safe conditions before any maintenance work is started.
- Observe the expertise required for the various routine and extraordinary maintenance operations.

Failure to observe the warnings may result in risks to personnel.

Routine maintenance

Switch off the power supply to the machine before cleaning the equipment.
The machine must not be cleaned with water jets or steam cleaners.

Cleaning the machine and accessories

- Pay attention to the choice and use of cleaning agents in order to maintain proper performance and safety of the equipment.

- Before use, clean all internal parts and accessories with lukewarm water and neutral soap or with products that are more than 90% biodegradable (in order to reduce the emission of pollutants into the environment), then rinse and dry thoroughly. Where possible, use the dishwasher for cleaning.
- Do not use detergents containing chlorine, solvent-based detergents (such as trichloroethylene etc.), powders or abrasive agents, scouring pads or sponges to clean the equipment, as these may damage the surfaces. Avoid the use of organic solvent substances or essential oils. These substances could affect the synthetic elements of the equipment.
- Do not use products (even if diluted) containing chlorine (sodium hypochlorite, hydrochloric acid, muriatic acid, etc.) to clean the flooring under equipment.
- Take particular care when using the needle probe, bearing in mind that it is a sharp object that must be handled with particular care when cleaning.

Preventive maintenance

- In order to ensure machine safety and performance, it is advisable to have maintenance operations carried out by Angelo Po specialised personnel every 12 months, in accordance with the Angelo Po service manuals. For further details, please contact your local Angelo Po Service Centre.

Repairs and extraordinary maintenance

- Repairs and extraordinary maintenance must only be carried out by specialised and authorised personnel. The manufacturer declines all liability for any failure or damage caused by the intervention of technicians not authorised by the manufacturer and the local original manufacturer's warranty.

Spare parts and accessories

- Only use original accessories and/or spare parts. The use of non-original accessories and/or spare parts will invalidate the manufacturer's warranty and may render the machine non-compliant with safety standards.

Maintenance intervals

- Maintenance intervals depend on the actual operating conditions of the machine and the environmental conditions (presence of dust, humidity, etc.), so no definite time intervals can be given. However, it is advisable to carry out scrupulous and regular machine maintenance in order to keep service interruptions to a minimum.

Maintenance, inspections, checks and cleaning	Frequency	Responsible
Routine cleaning • General cleaning of the machine and surrounding area	Daily	Operator
Mechanical protective devices • Check the conditions and verify that there are no deformations, loosening or removals	Every 6 months	Service
Control • Check that there are no cracks or deformations, tightening of screws on the mechanical part: check the legibility and condition of inscriptions, stickers and symbols and restore them if necessary	Annual	Service
Machine structure	Annual	Service

<ul style="list-style-type: none"> • Tightening of main bolts (screws, fastening systems, etc.) on machine 		
Safety signs <ul style="list-style-type: none"> • Check legibility and conditions of safety signs 	Annual	Service
Electrical control panel <ul style="list-style-type: none"> • Check the conditions of the electrical components installed inside the electrical control panel. Check the wiring between the electrical control panel and the machine parts. 	Annual	Service
Electrical connection cable <ul style="list-style-type: none"> • Check the conditions of the connection cable (replace if necessary) 	Annual	Service
General overhaul of the machine <ul style="list-style-type: none"> • Check all components, electrical equipment, corrosion, piping etc. 	Every 10 years ⁽¹⁾	Service

tab 5

(1) - the machine has been built and designed to last for approximately 10 years. After this period (from commissioning) a general overhaul of the machine should be carried out.

- It is advisable to enter into a preventive and scheduled maintenance contract with Customer Service.

WARRANTY TERMS AND EXCLUSIONS

If the purchase of this equipment includes warranty coverage, it is provided in accordance with local regulations and on the condition that the product is installed and used for the purposes intended and described in the corresponding equipment documentation.

The warranty is applicable if the user has used only original spare parts and has performed maintenance in accordance with Angelo PO maintenance and user documentation made available in hard copy or electronic format.

Angelo Po recommends the use of Angelo Po approved detergents, rinsing agents and descaling agents to achieve optimum results and to maintain the efficiency of the product over time.

The Angelo Po warranty does not cover:

- Costs of service trips for delivery and collection of the product;
- Installation;
- Training on how to use/operate the product;
- Replacement (and/or supply) of damaged parts subject to wear and tear, unless this is due to defects in material or workmanship reported within one week of failure;
- Correction of external wiring;
- Correction of unauthorised repairs as well as any damage, faults or inefficiencies caused by and/or resulting from:
 - Insufficient capacity and/or faults in electrical installations (current/voltage/frequency, including spikes and/or interruptions);
 - Inadequate or interrupted water, steam, air, gas supply (including impurities and/or other factors not in accordance with the technical requirements of each machine);
 - Consumable hydraulic parts, components or cleaning products not approved by the manufacturer;
 - Negligence, misuse, abuse and/or non-compliance by the user with the operating and care instructions described in the equipment documentation;
 - Improper or poor installation, repair, maintenance (including tampering, modifications and repairs carried out by unauthorised third parties) and modification of safety systems;
 - Use of non-original components;
 - Environmental conditions that cause thermal stress (e.g. overheating (chilling) or chemical stress (e.g. oxidation/corrosion));
 - Foreign objects placed on or attached to the product;
 - Accidents or force majeure;
 - Transport and handling, including scratches, dents, chips, and/or other damage to the finish of the product, unless such damage results from defects in material or workmanship and is reported within one week after delivery unless otherwise agreed upon;
 - Replacement of lamps, filters or any consumable parts;
 - Any accessories or software not approved or specified by Angelo Po;

The warranty does not include scheduled maintenance (including parts required to perform such maintenance) or the supply of cleaning agents, unless this is expressly covered by a local agreement in accordance with local conditions.

GENERAL INFORMATION



WARNING

Refer to the chapter "Safety warnings and information".

INTRODUCTION

The following provides information on the intended use of this equipment, its testing, and describes the symbols used (which mark and allow you to recognise the type of warning), definitions of terms used in the manual, and a range of useful information for equipment users.

ADDITIONAL INSTRUCTIONS

Please note that the drawings and diagrams in the manual are not to scale. They serve to supplement the written information and act as a summary to it but are not intended as a detailed representation of the machine supplied.

The numerical values represented in the equipment installation diagrams are expressed in millimetres or inches.

INTENDED USE AND RESTRICTIONS

This machine is designed for quick blast-chilling, food preservation (quickly lowering the temperature of cooked food to preserve its initial qualities and ensure its shelf life for several days), cooking, leavening and thawing of food.

Any other use is to be considered improper.



CAUTION

The machine is not suitable for installation outdoors and/or in environments subject to weathering (rain, sun, etc.).



NOTE

The manufacturer accepts no liability for improper use of the machine

EQUIPMENT IDENTIFICATION / NAMEPLATE DATA

Make sure the technical wiring specifications comply with the ratings (i.e., V, kW, Hz, no. phases and mains power).

Please quote the product's serial number (shown on the rating plate) on any enquiry to the Manufacturer.

①				②				③				④				⑤				⑥				⑦			
A ~ B C D				N				S T M				E				G H L				F							
A ~ B C D				P				G H L				F				G H											
~				W				Z																			



List of rates shown on the rating plate:

- | | |
|---|--|
| <ul style="list-style-type: none"> 1) Model 2) Manufacturer's name and address 3) CE mark 4) Year of make 5) Serial number 6) Power insulation class 7) Electrical device casing protection rating A) Input voltage B) Electric current intensity C) Frequency D) Rated power E) Total lamp power | <ul style="list-style-type: none"> F) Fuse current G) Coolant type H) Coolant q.ty L) Temperature grade M) Max hydraulic supply pressure N) Cabinet temperature P) Expanding fluid R) WEEE Symbol S) Heater presence T) Heater power W) Heating element power Z) Minimum pressure AA) Water consumption |
|---|--|

TESTING

Our equipment is designed and verified through laboratory tests to ensure guaranteed performance and efficiency.

The equipment is delivered to be ready for use.

Passing the tests (visual test, electrical test, functional test) is guaranteed by means of the specific annexes.

Should the appliance have been transported horizontally instead of a vertical position **DO NOT START THE APPLIANCE IMMEDIATELY. WAIT FOR AT LEAST 24 HOURS BEFORE OPERATING.** ***The manufacturer declines any responsibility and any warranty obligation if damage occurs to the equipment imputable to transportation in a horizontal position.***

Respect the machine's operating conditions: outside temperatures must be between 15°C and 40°C.

Switch on the unit and wait 30 minutes before use if the outside temperature is "low".

Check absorption

Carry out at least one complete blast-chilling cycle in order to verify correct operation

Make sure that the room has proper air exchange.

Model	Air quantity [m ³ /h]
51...	1.100
101L	3.500
141L-171L	4.300
102	4.300

(tab 6)

COPYRIGHTS

This manual is intended exclusively for consultation by operators and may only be handed over to third parties with the permission of the company Angelo PO.

STORING THE MANUAL

The manual must be kept intact for the entire life of the machine up to its demolition. If the machine is transferred, sold, hired, leased or rented out, the manual must accompany the machine itself.

INTENDED AUDIENCE OF THE MANUAL

The manual is intended for:

- The transporter and handling personnel;
- Installation and commissioning personnel;
- The employer of the machine users and the person in charge of the workplace;
- The operators assigned to use the machine;
- Specialised personnel – Customer Service

DEFINITIONS

Definitions of the main terms used in the manual are listed below. Careful reading is recommended before use.

Operator	Person responsible for installing, adjusting, using, maintaining, cleaning, repairing and transporting the machine.
Manufacturer	Angelo Po or any other service centre authorised by Angelo Po.
Ordinary machine operator	Operator who has been informed, trained and instructed about the tasks to be carried out and the risks involved in ordinary use of the machine.
Customer service or specialised personnel	An operator instructed/trained by the Manufacturer who, on the basis of his/her professional training, experience, specific training, knowledge of accident prevention regulations, is able to assess the work to be carried out on the machine and recognise and avoid risks. His/her professionalism covers the fields of mechanics, electrical engineering, electronics, etc.
Hazard	Source of possible injury or damage to health.
Hazardous situation	Any condition in which an Operator is exposed to one or more hazards.
Risk	Combination of probability and severity with possible injury or damage to health in a hazardous situation.
Protections	Safety measures consisting of the use of specific technical means (guards and safety devices) to protect Operators from Hazards.
Guard	An element of a machine used specifically to provide protection by means of a physical barrier.
Safety device	Device (other than a Guard) that eliminates or reduces a Risk; it may be used alone or be combined with a Guard.

User	The person who has purchased the machine and/or who operates and uses it (e.g. company, contractor, business).
Electrocution	Accidental discharge of electric current onto the human body.

(tab 7)

RESPONSIBILITY

No liability is accepted for damage or malfunctions caused by:

- Failure to comply with the instructions given in this manual;
- Repairs carried out incorrectly and replacement of spare parts other than those specified in the spare parts catalogue (the assembly and use of non-original spare parts and accessories may adversely affect operation of the machine and invalidate the original manufacturer's warranty);
- Operations carried out by non-specialised personnel;
- Unauthorised modifications or interventions;
- Lack of or inadequate maintenance;
- Improper use of the machine;
- Unforeseeable exceptional events;
- Use of the machine by uninformed and/or untrained personnel;
- Failure to apply the provisions in force in the country of use regarding safety, hygiene and health in the workplace.

No liability is accepted for damage caused by arbitrary conversions and modifications by the user.

Responsibility for the identification and selection of appropriate, suitable personal protective equipment, to be worn by the operators, is the responsibility of the employer or the person in charge of the workplace or the service technician, in accordance with the regulations in force in the country of use.

The manufacturer declines all liability for inaccuracies in the manual if they are attributable to printing or translation errors.

Any additions to the installation, operation and maintenance manual which the Manufacturer deems appropriate to send to the user must be kept together with the manual, of which they will form an integral part.

LIST OF REGULATION REFERENCES

The cooling cabinet we manufacture fully complies with the following European and national regulations:

2006/42/EC (machine regulations)
 2004/30/EU (EMC regulation)
 2014/68/EU (PED regulation)
 2011/65 (RoHS2 regulation)
 2015/1094/EU (Energy labelling)
 2015/1095/EU (Ecodesign)
 2015/863 (ROHS III)
 108/89 CEE
 1935/2004 EU

D.M. 15-06-71 (Italy)
 D.L. n°110 27-01-92 (Italy)
 J.O. 16-07-74 n°74-163 (France)

and the following European regulations:

EN55014-1;EN55104-2
 EN61000-3-2 ; EN61000-3-3
 EN60335-1;EN60335-2-89
 EN378-I-II
 EN22042

NORMAL USE OF THE MACHINE



WARNING

Refer to the chapter “Safety warnings and information”

CHARACTERISTICS OF PERSONNEL TRAINED IN ROUTINE USE OF THE MACHINE

The user must make sure that those assigned to routine use of the machine are suitably trained and demonstrate competence in carrying out their tasks, taking care of their own safety and that of third parties.

The user must check that personnel has understood the instructions they have received, in particular those concerning aspects of safety and hygiene in the workplace when using the machine.

CHARACTERISTICS OF PERSONNEL AUTHORISED TO WORK ON THE MACHINE

It is the user's responsibility to check that the persons assigned to the various tasks have the following requisites:

- Have read and understood the manual;
- Training and instruction appropriate to their tasks in order to perform them safely;
- Specific training for correct use of the machine.

THE OPERATOR IN CHARGE OF ROUTINE USE

Must have at least:

- Knowledge of technology and specific experience of operating the machine;
- Basic general and technical knowledge at a level sufficient to read and understand the contents of the manual, including the correct interpretation of signs, drawings and pictograms;
- Sufficient knowledge to safely carry out the tasks for which he/she is responsible as specified in the manual;
- Knowledge of occupational health and safety regulations.

Should any substantial anomaly occur (e.g. short circuits, evidence of cables outside the electrical panels, motor failure, deterioration of the protective sheaths of electrical cables, etc.), the operator in charge of routine use of the machine must:

- Switch off the machine immediately.

TRANSPORTATION AND HANDLING

For transportation and handling, all precautions necessary must be taken in order not to damage the equipment, referring to the indications found on the packaging of the same. Make sure that the consignment has not been tampered with or damaged during transport.

UNPACKING

Installation must be carried out by authorised and specialised personnel.

After removing the packaging, ensure the integrity of the equipment and verify that all the parts or components are present and that the characteristics and state correspond to the specifications of the your order.

If not, please inform the retailer immediately.

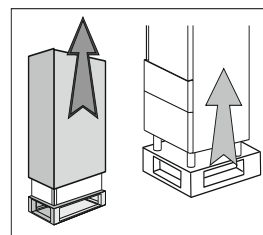

Remove pvc protective film from all over the appliance.

Attention: all the packing material must be disposed of in accordance with the prevailing regulations in the country where the equipment is used and in any case must not be dispersed into the environment.

POSITIONING

The appliance must be installed and tested in full compliance with accident-prevention regulations contained in national law and current guidelines. Installers are to comply with any current local regulations.

- Place the appliance onto the required working site.

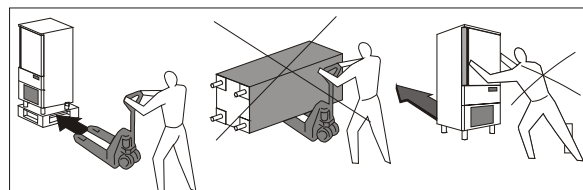

- Avoid locations with exposure to direct sunlight.
- Do not place the appliance in hot, poorly-ventilated rooms.
- Do not place the refrigerated compartment near heat sources.

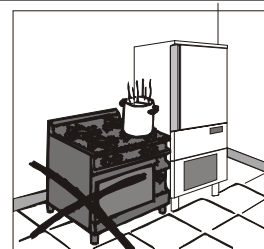

- Leave a min. 100-mm clearance around the appliance on the sides where air inlet and outlet are located.

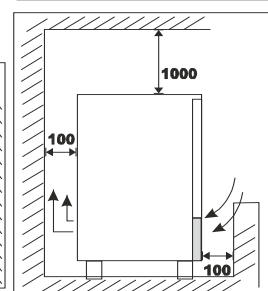
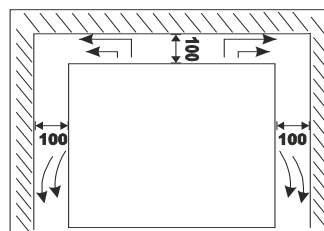

- Level the appliance by means of adjustable feet.

WARNING: If the appliance is not properly levelled the performance and condensate drain may be hampered.

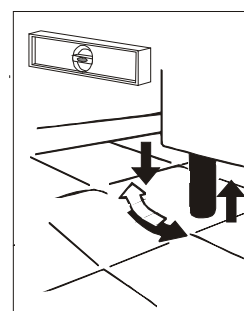

DIMENSIONS

Please refer to the dimensions of your own appliance.

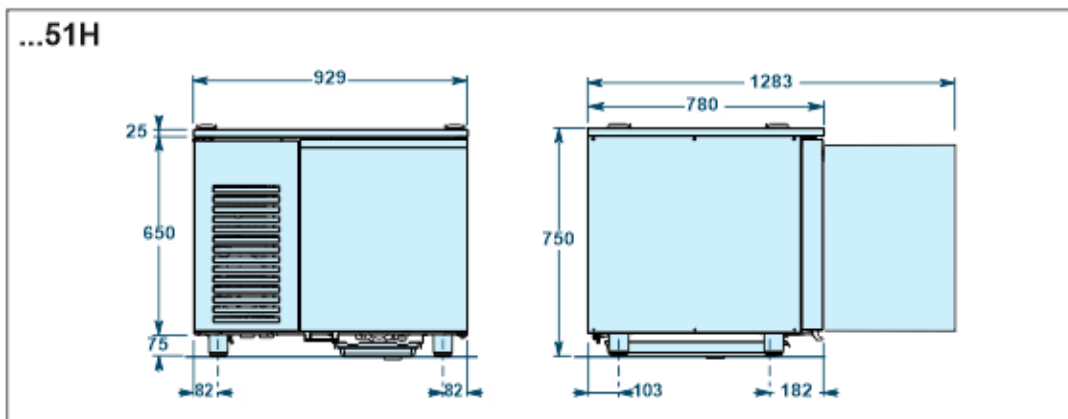
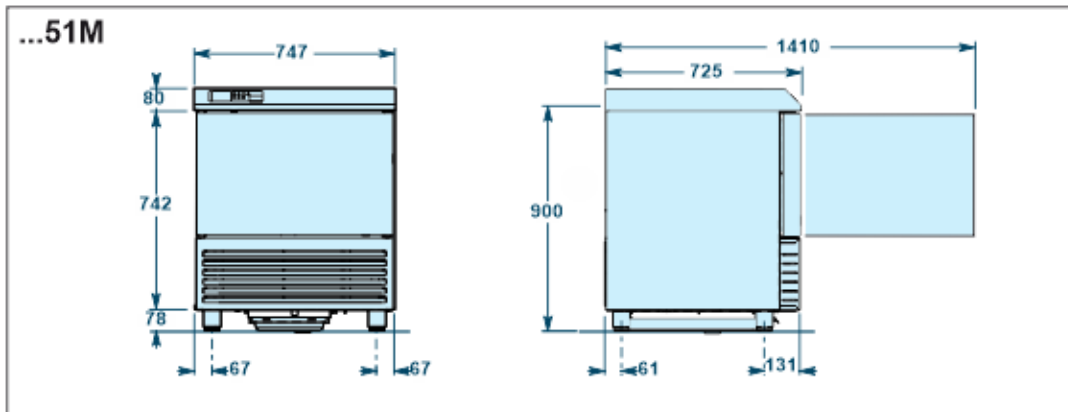
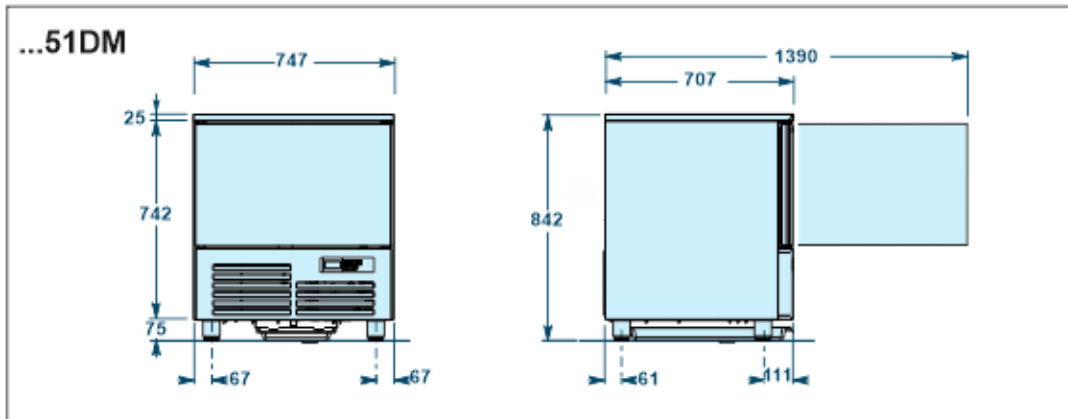
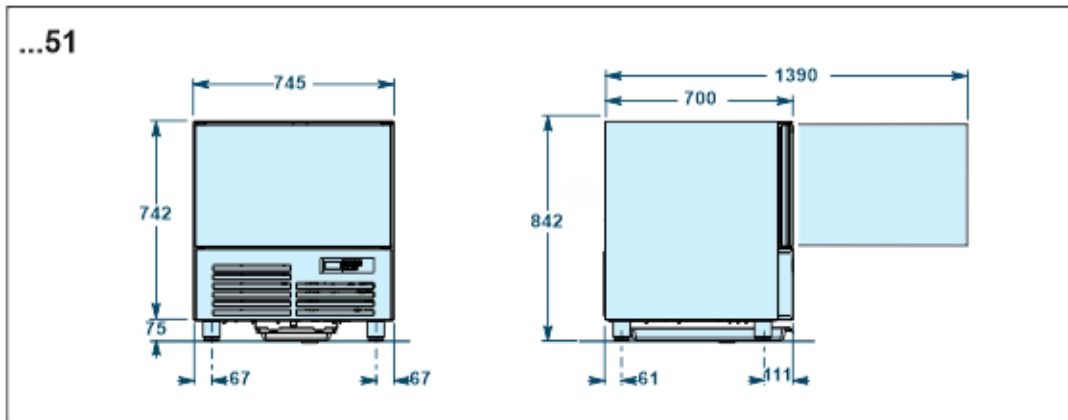

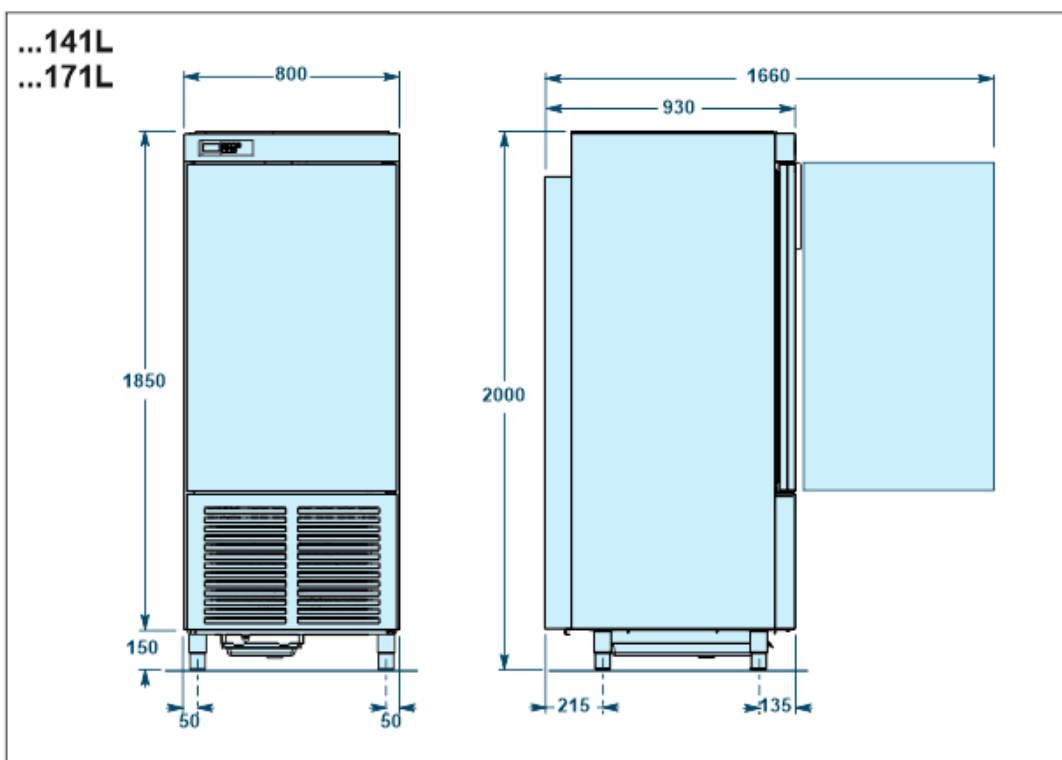
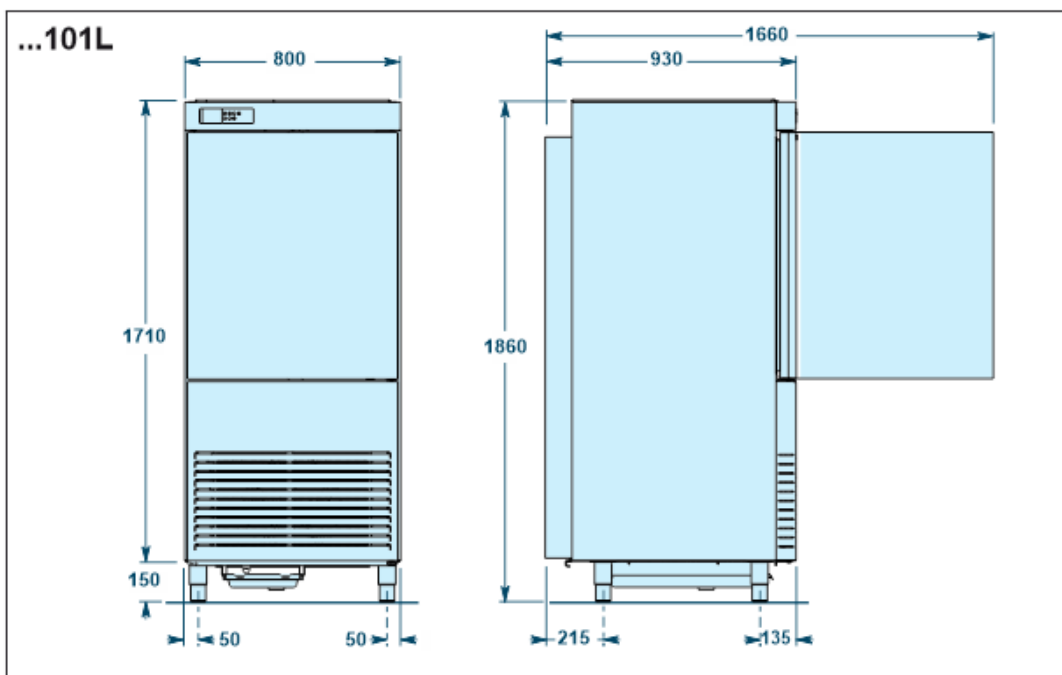

...102

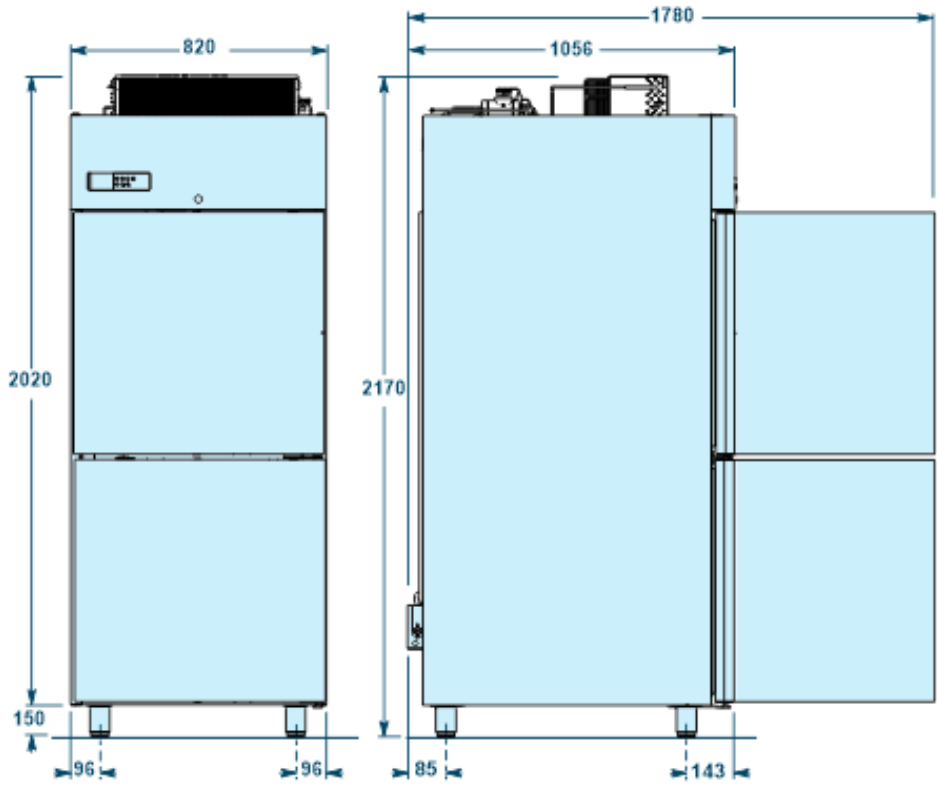

TECHNICAL DATA

Please refer to the technical data of your own appliance.

Model	...51H	...51DM	...51...	...101L	...141L/...171L
Gross weight	135	95	95/100	200	270
Net weight	120	85	85/90	175	245
Dimensions	929x780x750	747x707x842	745x700x820 747x725x900	800x930x1860	800x930x2000
Capacity					
Mass /cycle [kg] (+90°C ÷ +3°C)	15	18	20	45	70
Mass /cycle [kg] (+90°C ÷ -18°C)	7	10	12	28	38
Internal volume [l]	90	90	90	195	270
Rails	GN1/1	GN1/1 600x400	GN1/1 600x400	GN1/1 600x400	GN1/1 600x400
Trays	5	5	5	10	14/17
Power supply					
Voltage [V]	230V 1N~	230V 1N~	230V 1N~	400V 3N~	400V 3N~
Frequency [Hz]	50	50	50	50	50
Intensity [A]	3	3,6	3,6	4,4	5
Power input [W]	570	770	820	1900	2500
Refrigerating unit					
Refrigerating power [W]	611 (A)	897 (A)	897 (A)	935+935 (A)	1317+1317 (A)
Evaporation temperature [°C]	-23,3	-23,3	-23,3	-23,3	-23,3
Cooling temperature [°C]	+90÷+3	+90÷+3	+90÷+3	+90÷+3	+90÷+3
Cooling time [min]	90	90	90	90	90
Freezing temperature [°C]	+90÷-18	+90÷-18	+90÷-18	+90÷-18	+90÷-18
Freezing time [min]	240	240	240	240	240
Condensation temperature [°C]	+54,5	+54,5	+54,5	+54,5	+54,5
Max room temperature [°C]	+32	+32	+32	+32	+32
Compressor type	Ermetic	Ermetic	Ermetic	Ermetic	Ermetic
Coolant	R290	R290	R290	R290	R290
Coolant qty [g]	100	70	80	150+150	150+150
Condensation air	Air	Air	Air	Air	Air
Noise [dB] (A)	60	60	60	64	64
Sonda monopoint NTC	•	•	•	•	•

Model	HPC51M	HPC101L	HPC171L	HPC102
Gross weight	125	225	270	243
Net weight	115	200	245	223
Dimensions	747x725x900	800x930x1860	800x930x2000	820x1056x2170
Capacity				
Mass /cycle [kg] (+90°C ÷ +3°C)	20	30	38	38
Mass /cycle [kg] (+90°C ÷ -18°C)	90	195	270	270
Internal volume [l]	36x16,5x12	36x16,5x12	36x16,5x12	36x16,5x12
Rails	6	12	18	40
Trays				
Power supply	230V 1N~	400V 3N~	400V 3N~	400V 3N~
Voltage [V]	50	50	50	50
Frequency [Hz]	4,5	4,4	5	4,4
Intensity [A]	950	1900	2500	2600
Power input [W]				
Refrigerating unit	1317 (A)	1317+1317 (A)	1317+1317 (A)	1317+1317 (A)
Refrigerating power [W]	-23,3	-23,3	-23,3	-23,3
Evaporation temperature [°C]	+90÷+3	+90÷+3	+90÷+3	+90÷+3
Cooling temperature [°C]	90	90	90	90
Cooling time [min]	+90÷-18	+90÷-18	+90÷-18	+90÷-18
Freezing temperature [°C]	240	240	240	240
Freezing time [min]	+54,5	+54,5	+54,5	+54,5
Condensation temperature [°C]	+32	+32	+32	+32
Max room temperature [°C]	Ermetic	Ermetic	Ermetic	Ermetic
Compressor type	R290	R290	R290	R290
Coolant	150	150+150	150+150	150+150
Coolant qty [g]	Air	Air	Air	Air
Condensation air	60	64	64	64
Sonda monopoint NTC	•	•	•	•

(A) – Ashrae conditions
(B) – Cecomaf conditions

ELECTRICAL CONNECTION

The electrical connection and connection systems of the unit must comply with the regulations in force in the country of installation and must be carried out by qualified personnel authorised by the manufacturer.

Maximum permissible impedance

The machines must be connected to a public distribution system with a maximum permissible system impedance of 0,311 Ohm.

CAUTION: do not use adapters or extension cords for connection to the mains.

DO NOT USE ADAPTER PLUGS. Due to safety hazards that may arise in certain situations, the use of adapter plugs is strongly discouraged.

DO NOT USE EXTENSION CORDS. The manufacturer does not guarantee the unit if an extension cord is used.

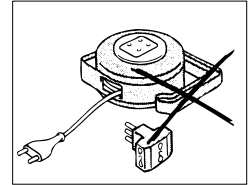

WARNING: any damaged power cord must be replaced by the manufacturer, after-sales service, or qualified personnel to prevent risks.

Check that the mains voltage corresponds to the voltage stated on the technical rating plate of the unit.

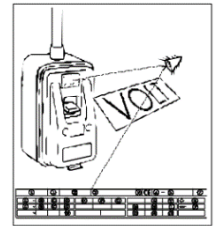

CAUTION: The unit must be connected to an effective earthing system .

CAUTION: It is compulsory to insert the unit into an equipotential system according to the regulations in force. The connection must be made between the different units via the equipotential terminal .

CAUTION: An omnipolar switch is to be installed before the appliance, in compliance with the current regulations applied in the country where the appliance is installed.

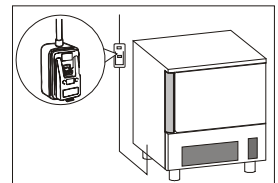

The electrical mains cables must be correctly sized and selected based on the installation conditions.

The electrical connection is carried out from the rear part.

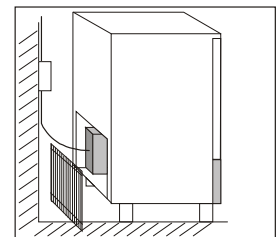

Models 51... have 3m of three-pin cable (3G 1.5mm²) with a SHUKO type plug. Use of any other type of electrical connection or modifying the size of the cable by less than its length is not permitted. Take care to replace it, if necessary, with one having identical characteristics to the original.

Models 101L-141L-171L-102 are provided with 3.5m of pentapolar cable for three-phase power supply (5G 2.5mm²) without a plug. Fit an electrical plug (not supplied) of a type and capacity suitable for the maximum current absorbed by the unit or make a direct connection to an electrical panel.

The guarantee will cease and the Manufacturer will not be liable for any damage to appliances or operators arising from the non-compliance with the and tamperings to any part of the appliance (electric, thermodynamic or hydraulic plant).

CONTROL AND SAFETY SYSTEMS

The following information concerns skilled staff only.

- **Door micro-switch:** Prevents the appliance from working when the door is open
- **Overall protection fuses:** Protect the whole power circuit from and short-circuits and overloads
- **Compressor thermal relay:** Operates in case of an overload or working failures
- **Bimetallic safety thermostat:** intervenes in the event of excessively high temperature in the inside compartment.
- **Fan Motor Protector:** intervenes in the event of overload or malfunction.
- **Safety pressure-switch:** Operates in case of coolant over-pressure
- **Cabinet temperature control:** Is run by NTC probe through the relevant electronic card
- **Core temperature control:** Is run by NTC probe through an electronic card
- **Electronic boards:** based on the parameters entered they command and control any devices connected to the equipment.

REFRIGERANT MATERIAL SAFETY DATA SHEET

R600a o R290

GWP = 3

ODP = 0

❖ Hazards identification

Liquefied gas - Extremely flammable

❖ First aid measures

• *Inhalation:*

In high concentrations may cause asphyxiation. Symptoms may include loss of mobility and/or consciousness. Victims may not be aware of asphyxiation. In low concentrations, may cause narcotic effects. Symptoms may include dizziness, headache, nausea and loss of coordination. Remove victim to an uncontaminated area wearing self contained breathing apparatus. Keep the patient relaxed and warm. Call a physician. Apply artificial respiration if breathing stops.

• *Contact with skin and eyes:*

In case of spillage, rinse thoroughly with water for at least 15 minutes

- *Ingestion:*
Route of exposure unlikely

❖ Informazioni ecologiche
Ecological information No known ecological damage caused by this product.

DISPOSAL

WASTE STORAGE

At the end of the product life, avoid release to the environment. The doors should be removed before disposal. Temporary storage of special waste is permitted while waiting for disposal by treatment and/or final collection. Dispose of special waste in accordance with the laws in force with regard to protection of the environment in the country of the user.

PROCEDURE FOR ROUGH DISMANTLING THE APPLIANCE

All countries have different legislation; provision laid down by the laws and the authorised bodies of the countries where the demolition takes place are therefore to be observed. A general rule is to deliver the appliance to specialised collection and demolition centres. Dismantle the refrigerator grouping together the components according to their chemical nature. The compressor contains lubricating oil and refrigerant, which may be recycled. The refrigerator components are considered special waste, which can be assimilated with domestic waste. Make the appliance totally unusable by removing the power cable and any door locking mechanisms in order to avoid the risk of anyone being trapped inside.

DISMANTLING OPERATIONS SHOULD BE CARRIED OUT BY QUALIFIED PERSONNEL.

THE SAFE DISPOSAL OF WASTE FROM ELECTRICAL AND ELECTRONIC EQUIPMENT (WEEE DIRECTIVE 2002/96/EC)

Do not dump pollutant material in the environment. Dispose of it in compliance with the relevant laws.

Under the WEEE (Waste Electrical and Electronic Equipment) Directive 2002/96/EC, when scrapping equipment the user must dispose of it at the specific authorised disposal centres, or reassign it, still installed, to the original seller on purchase of new equipment. All equipment which must be disposed of in accordance with the WEEE Directive

2002/96/EC is marked with a special symbol .

The improper disposal of Waste Electrical and Electronic Equipment is liable to punishment under the relevant laws in the countries where the offence is committed.

Waste electrical and Electronic Equipment may contain hazardous substances with potential harmful effects on the environment and human health. You are urged to dispose of them properly.

OPERATION

SETTING UP

Before setting to operation thoroughly clean the cooling cabinet with a suitable detergent or sodium bycarb dissolved in lukewarm water. Clean the appliance inside to remove any condensate caused by the Manufacturer's final testing.

- a) Cooling and freezing speed depends on the following factors:
- b) container shape, type and material;
- c) whether container lids are used;
- d) foodstuff features (density, water contents, fat contents);
- e) starting temperature;
- f) thermal conduction inside the foodstuffs

Positive /Negative quick cooling time depends on type of foodstuffs to be processed.

In general the programmes the machine is equipped with are based on the chamber temperature management, the fan speed and the chilling time, in any case never exceed 5kg of load (for GN1/1, EN1/1 or 60x40 pans) or 10kg of load (for GN2/1, EN2/1 or 60x80 pans) and a thickness of 50mm in negative chilling phase and 80mm in positive chilling phase (tab.10).

We recommend pre-chilling the work chamber before beginning with a chilling programme and not covering the food during the programme in order not to increase times.

We recommend using the core probe in order to have the exact core temperature reading. Do not stop the cycle before reaching a temperature of +3°C during positive quick cooling and -18°C during negative quick cooling.

Model	Max. output/cycle		Capacity			h mm
	+90[°C]÷+3[°C]	+90[°C]÷-18[°C]	n° max	GN	EN	
...51H	15[kg]	7[kg]	5	1/1	600X400	40
...51DM	18[kg]	10[kg]	5	1/	600X400	40
...51-...51M	20[kg]	12[kg]	5	1/1	600X400	40
...101L	45[kg]	28[kg]	10	1/1	600X400	40
...141L-...171L	70[kg]	38[kg]	14	1/1	600X400	40

Model	Max. output/cycle	Capacity		h mm
		n° max	cm	
	-18[°C]÷-9[°C]			
...51M	20[kg]	6	36x16,5	12
...101L	30[kg]	12	36x16,5	12
...171L	38[kg]	18	36x16,5	12
...102	38[kg]	40	36x16,5	12

(tab 10)

MACHINE LOADING

Do not pile up foodstuffs to be cooled. Thickness should be lower than 50mm in negative quick cooling and lower than 80mm in positive quick cooling.

Make sure air circulation is not hampered between food trays.

The grid-holding frame (included in those models which include trolleys) is to be located at the centre of the cabinet.

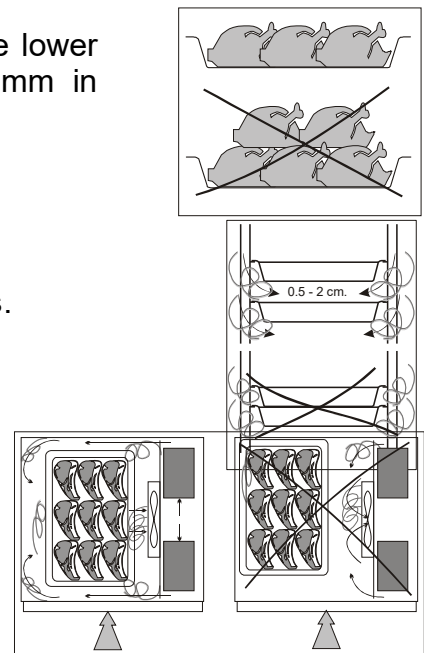

POSITION OF TRAYS

Place the trays as close to the evaporator as possible.

If the cabinet is not full place the trays at equal distance from one another.

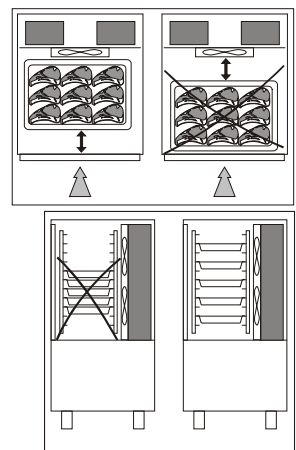

CORE PROBE

For proper position of the probe, refer to the following pictures.

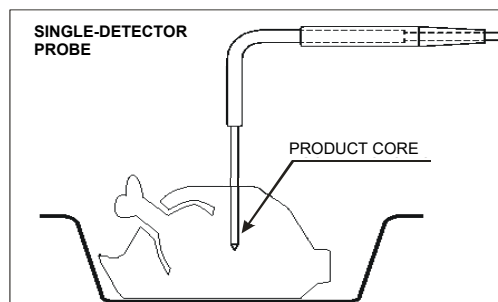

TEMPERATURES

Avoid leaving cooked products at room temperature.

It is advisable to start the blast-chilling/blast-freezing program as soon as the preparation or cooking phase has ended, taking care to place the product in the unit at a temperature no lower than +70°C. You can place the cooked product in the unit even at very high temperatures, above +100°C, as long as the cabinet has been pre-cooled.

LENGTH

Cooled or frozen processed foodstuffs may be stored in a refrigerator for 5 days of processing with no quality alterations.

For best results we recommend keeping temperature constant throughout the storing (0°C to 4°C), according to the various commodities.

Storing time may be increased to approx. two weeks by using vacuum processing.

After a negative quick cooling cycle, foodstuffs may be stored safely for 3 to 18 months, according to the type of foodstuff processed.







We strongly recommend keeping storing temperature at -20°C or below.

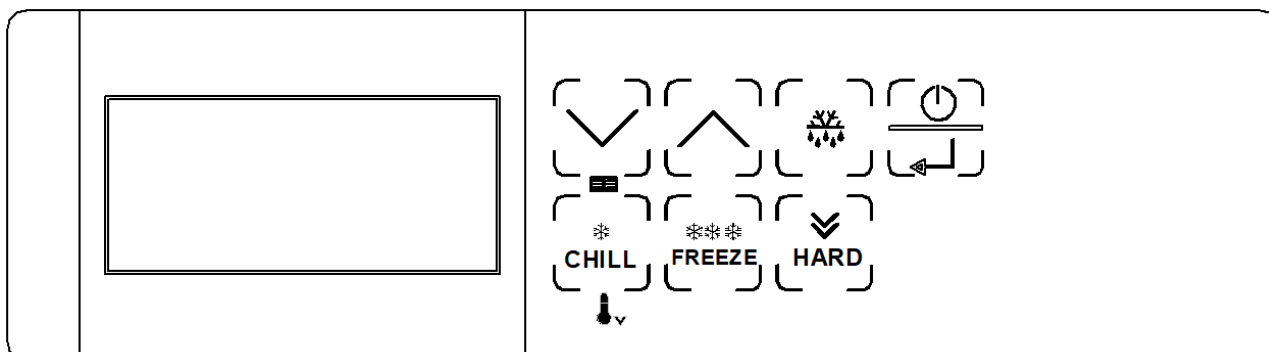

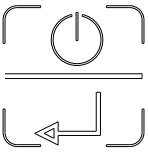



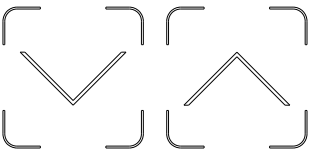



The cooled product should be wrapped in a specific film for foodstuffs (better still, vacuum stored) and provided with a sticker reporting the content [A], date of processing [B] and expiry date [C] written in permanent type ink.

CONTROL PANEL

The illustration shows the equipment control panel, while the list indicates the description and functionality of the individual commands.



	<p><u>STANDBY/ON KEY</u> <i>With the card on standby:</i></p> <ul style="list-style-type: none"> • hold the button down for 1 sec to switch the tab page on <p><i>With the card on stop and the cycle selected:</i></p> <ul style="list-style-type: none"> • press this key once to start the cycle <p><i>With the card set on cycle running:</i></p> <ul style="list-style-type: none"> • press the button once to stop the cycle <p>NOTE: <i>If you hold this key pressed for 3 seconds, you can set the card to Off from any mode.</i></p>
	<p><u>POSITIVE SOFT QUICK COOLING KEY</u> <i>With the card on stop:</i></p> <ul style="list-style-type: none"> • press this key once to select a positive soft quick cooling cycle
	<p><u>NEGATIVE QUICK COOLING KEY</u> <i>With the card on stop:</i></p> <ul style="list-style-type: none"> • press this key once to select a negative quick cooling cycle
	<p><u>HARD QUICK COOLING KEY</u> <i>With selected blast chill cycle</i></p> <ul style="list-style-type: none"> • press the button once to select the positive/negative/Hard chilling cycle
	<p><u>DEFROST KEY</u> <i>With the card on stop:</i></p> <ul style="list-style-type: none"> • hold the button down for 4 seconds to run a defrosting cycle (if necessary)
	<p><u>UP AND DOWN KEYS</u> Use these keys to increase or decrease values <i>With the card on stop:</i></p> <ul style="list-style-type: none"> • hold the  button down for 1 sec to access the probe display menu

	<u>POSITIVE QUICK COOLING LED</u> It is on during positive blast chilling and blinking during selection
	<u>NEGATIVE QUICK COOLING LED</u> It is on during negative blast chilling and blinking during selection
HARD	<u>HARD QUICK COOLING LED</u> It is on during hard chilling, blinking during selection, and on when the function is not active
	<u>CORE PROBE LED</u> It is on during a core probe cycle and blinking during selection or when warning that the needle is not inserted
	<u>TIME LED</u> It is on during a time-controlled cycle and blinking during selection
	<u>STORING LED</u> It is on during the stage after blast chill preservation and blinking during the cycle when the compartment probe is displayed
	<u>DEFROST LED</u> It is on during defrosting and blinking during dripping
	<u>LED PRE-COOLING</u> It is on or blinking during the pre-cooling cycle
	<u>ON/OFF LED</u> It is on when the card is set to stand-by; it is off in any other state of the card
	<u>FAHRENHEIT LED</u> Temperature is measured in Fahrenheit degrees
	<u>CELSIUS LED</u> Temperature is measured in Celsius degrees

PROGRAMME

- CORE PROBE POSITIVE SOFT QUICK COOLING CYCLE: cycle suitable for cooling foodstuffs with thickness lower than 4[cm] using a room temperature of about 0[°C]. The cycle is controlled by the core probe.
- CORE PROBE POSITIVE HARD QUICK COOLING CYCLE: cycle suitable for cooling foodstuffs with thickness exceeding 4[cm] using a room temperature ranging from -30[°C] to -5[°C]. The cycle is controlled by the core probe.
- CORE PROBE NEGATIVE SOFT QUICK COOLING CYCLE: cycle for blast freezing delicate food using an initial chamber temperature around 0[°C]. The cycle is controlled by the core probe.
- CORE PROBE NEGATIVE HARD QUICK COOLING CYCLE: cycle suitable for freezing foodstuffs using a room temperature of about -30[°C]. The cycle is controlled by the core probe.
- TIME-CONTROLLED POSITIVE SOFT QUICK COOLING CYCLE: cycle suitable for cooling foodstuffs with thickness lower than 4[cm] using a room temperature of about 0[°C]. The cycle is time-controlled.
- TIME-CONTROLLED POSITIVE HARD QUICK COOLING CYCLE: cycle suitable for cooling foodstuffs with thickness exceeding 4[cm] using a room temperature ranging from -30[°C] to -5[°C]. The cycle is time-controlled.
- TIME-CONTROLLED NEGATIVE SOFT QUICK COOLING CYCLE: cycle for blast freezing delicate food using an initial chamber temperature around 0[°C]. The cycle is time-controlled.
- TIME-CONTROLLED NEGATIVE HARD QUICK COOLING CYCLE: cycle suitable for freezing foodstuffs using a room temperature of about -30[°C]. The cycle is time-controlled.

NOTE: At the end of the quick cooling phase, the device starts the storing phase (+2[°C] at the end of the positive quick cooling; -22[°C] at the end of the negative quick cooling).

Cooling time

FOODSTUFF	SHEET	MAX. LOAD	PRODUCT THICKNESS	QUICK COOLING TIME	ROOM TEMPERATURE	CORE TEMPERATURE
FIRST COURSES						
Bechamel	GN1/1 h60	6 lt	4 cm	70 minutes	-20 °C	3°C
Meat broth	GN1/1 h110	8 lt	6-7 cm	110 minutes	-20 °C	3°C
Cannelloni	GN1/1 h40	4 Kg	3-4 cm	40 minutes	-20 °C	3°C
Vegetable soup	GN1/1 h100	5 lt	5 cm	100 minutes	-20 °C	3°C
Fresh pasta	GN1/1 h40	1 Kg	5 cm	20 minutes	-20 °C	3°C
Meat and tomato sauce	GN1/1 h60	5 Kg	5 cm	90 minutes	-20 °C	3°C
Bean soup	GN1/1 h60	5 Kg	5 cm	100 minutes	-20 °C	3°C
Fish soup	GN1/1 h60	4 Kg	5 cm	110 minutes	-20 °C	3°C
MEAT AND POULTRY						
Roast pork	GN1/1 h60	8 Kg	10 cm	110 minutes	-20 °C	3°C
Braised beef	GN1/1 h60	8 Kg	15 cm	110 minutes	-20 °C	3°C
Boiler beef	GN1/1 h60	6 Kg	12-18 cm	110 minutes	-20 °C	3°C
Chicken breast	GN1/1 h40	5 Kg	4-5 cm	30 minutes	0 °C	3°C
Roast-beef	GN1/1 h40	4 Kg	10-15 cm	80 minutes	-20 °C	3°C
FISH						
Baked grouper	GN1/1 h40	3 Kg	5-10 cm	110 minutes	-20 °C	3°C
Squill	GN1/1 h40	2 Kg	3 cm	25 minutes	-20 °C	3°C
Vacuum-stored mussel	grid GN1/1	2 Kg	max 3-4 cm	20 minutes	-20 °C	3°C
Fish salad	GN1/1 h40	4 Kg	3-4 cm	30 minutes	0 °C	3°C
Boiled polyp	GN1/1 h60	5 Kg	-	60 minutes	-20 °C	3°C
Stewed cuttlefish	GN1/1 h60	4 Kg	4-5 cm	60 minutes	-20 °C	3°C
VEGETABLES						
Carrots trifolate	GN1/1 h60	4 Kg	4-5 cm	60 minutes	-20 °C	3°C
Mushrooms trifolati	GN1/1 h60	4 Kg	4-5 cm	60 minutes	-20 °C	3°C
Zucchini trifolate	GN1/1 h60	3 Kg	4-5 cm	90 minutes	-20 °C	3°C
PASTRY/DESSERT						
Vanilla / chocolate pudding	GN1/1 h60	6 lt	4-5 cm	90 minutes	0 °C	3°C
Creme anglaise	GN1/1 h60	3 lt	4-5 cm	100 minutes	0 °C	3°C
Custard a	GN1/1 h60	3 lt	4-5 cm	100 minutes	0 °C	3°C
Panna cotta (single portion)	grid	3 lt	6 cm	60 minutes	0 °C	3°C
Ice-cream cake	grid	3 Kg	4-6 cm	50 minutes	0 °C	3°C
Tiramisù	GN1/1 h60	5 Kg	4-5 cm	45 minutes	0 °C	3°C

PRE-COOLING CYCLE

It is advisable to run a cooling cycle prior to selecting any slaughter cycle.



Press  for 1 sec to run the pre-cooling cycle

The  icon blinks



The pre-cooling cycle continues once the temperature of -25 °C is reached in the chamber, the § remains steady, and the buzzer is activated for 1 sec.

CORE PROBE POSITIVE SOFT QUICK COOLING CYCLE



WARNING: insert the needle probe correctly to run a temperature-controlled cycle.



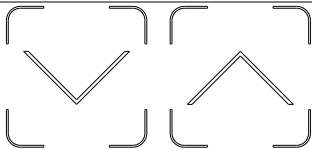

Press the  key to select a core probe positive Soft QC

The  and  icons blink
The display shows the room probe temperature setpoint during QC





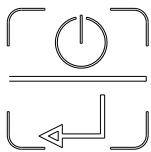

Press  or  within 15 seconds to change the value

Use the  and  keys to change the value



Press the  key to start the cycle

The  and  icons remain steady: the test is run to verify the insertion of the core probe

The cycle is run when the test is completed successfully; otherwise, a time-controlled positive soft chilling cycle will start. The  and  icons remain on.

CORE PROBE POSITIVE HARD QUICK COOLING CYCLE

WARNING: insert the needle probe correctly to run a temperature-controlled cycle.



Press the  key to select a core probe positive Soft QC



The  and  icons blink



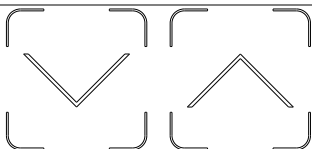

Press the  key to select a core probe positive Hard QC

The **HARD** icon blinks
The display shows the room probe temperature setpoint during QC



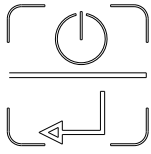

Press  or  within 15 seconds to change the value

Use the  and  keys to change the value



Press the  key to start the cycle

The ❄️ and  icons remain steady: the test is run to verify the insertion of the core probe

The cycle is run when the test is completed successfully; otherwise, a time-controlled positive hard chilling cycle will start. The ❄️ and  icons remain on

CORE PROBE NEGATIVE SOFT QUICK COOLING CYCLE





WARNING: insert the needle probe correctly to run a temperature-controlled cycle.



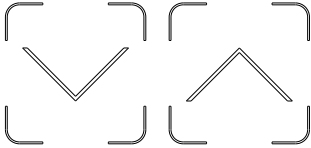

Press the  key to select a core probe negative Soft QC

The ❄️, ❄️❄️ and **HARD** and  icons blink
The display shows the room probe temperature setpoint during QC

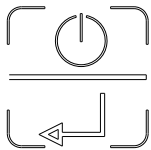

Press  or  within 15 seconds to change the value
Use the  and  keys to change the value



Press the  key to start the cycle

The ❄️, ❄️❄️, **HARD** and  icons remain steady: the test is run to verify the insertion of the core probe

The cycle is run when the test is completed successfully; otherwise, a time-controlled negative hard chilling cycle will start. The ❄️, ❄️❄️, **HARD**, and  icons remain on

CORE PROBE NEGATIVE HARD QUICK COOLING CYCLE

WARNING: insert the needle probe correctly to run a temperature-controlled cycle.



Press the  key to select a core probe positive Soft QC





The ❄️, ❄️❄️, **HARD** and  icons blink
The display shows the room probe temperature setpoint during QC



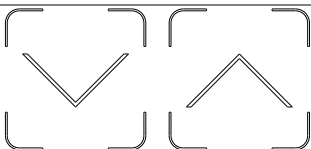

Press the  key to select a core probe negative Soft QC

The **HARD** icon turns off
The display shows the room probe temperature setpoint during QC

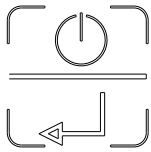

Press  or  within 15 seconds to change the value
Use the  and  keys to change the value



Press the  key to start the cycle

The ❄️, ❄️❄️ and  icons remain steady: the test is run to verify the insertion of the core probe

The cycle is run when the test is completed successfully; otherwise, a time-controlled negative soft chilling cycle will start. The ❄️, ❄️❄️, and  icons remain on

TIME-CONTROLLED POSITIVE SOFT QUICK COOLING CYCLE

WARNING: not insert the needle probe correctly to run a time-controlled cycle.



Press the  key to select a core probe positive Soft QC

The ❄️ and  icons blink
The display shows the room probe temperature setpoint during QC

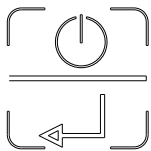





Press the  key to start the cycle

The ❄️ and  icons remain steady: the test is run to verify the insertion of the core probe

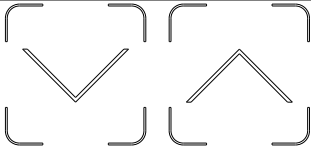
As the needle probe is not inserted, the test is not completed successfully and the time-controlled cycle is launched

The ❄️ and  icons remain steady
The display shows the remaining time of the cycle



Press  or  to change the value
Use the  and  keys to change the value

TIME-CONTROLLED POSITIVE HARD QUICK COOLING CYCLE

WARNING: not insert the needle probe correctly to run a time-controlled cycle.



Press the  key to select a core probe positive Soft QC

The ❄️ and  icons blink



Press the  key to select a core probe positive Hard QC

The **HARD** icon blinks
The display shows the room probe temperature setpoint during QC

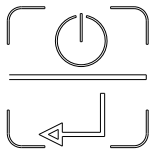

Press the  key to start the cycle

The ❄️,  and **HARD** icons remain steady: the test is run to verify the insertion of the core probe

As the needle probe is not inserted, the test is not completed successfully and the time-controlled cycle is launched

The ❄️, ⌚ and **HARD** icons remain steady
The display shows the remaining time of the cycle

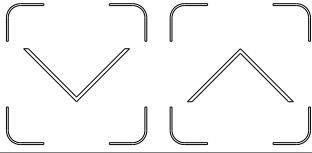

Press or to change the value
Use the and keys to change the value

TIME-CONTROLLED NEGATIVE SOFT QUICK COOLING CYCLE

WARNING: not insert the needle probe correctly to run a time-controlled cycle.



Press the key to select a core probe negative Soft QC

The ❄️, ❄️❄️, **HARD** and icons blink

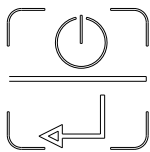

Press the key to start the cycle

The ❄️, ❄️❄️, **HARD** and icons remain steady: the test is run to verify the insertion of the core probe

As the needle probe is not inserted, the test is not completed successfully and the time-controlled cycle is launched

The ❄️, ❄️❄️, **HARD** and ⌚ icons remain on
The display shows the remaining time of the cycle

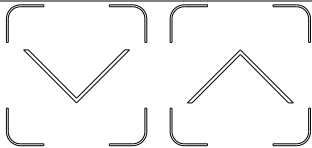

Press or to change the value
Use the and keys to change the value

TIME-CONTROLLED NEGATIVE HARD QUICK COOLING CYCLE

WARNING: not insert the needle probe correctly to run a time-controlled cycle.



Press the key to select a core probe negative Soft QC

The ❄️, ❄️❄️, **HARD** and icons blink



Press the key to select a core probe negative Hard QC

The **HARD** icon turns off
The display shows the room probe temperature setpoint during QC

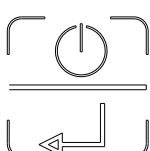

Press the key to start the cycle



The ❄️, ❄️❄️, and ⌚ icons remain steady: the test is run to verify the insertion of the core probe

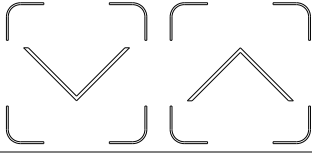

As the needle probe is not inserted, the test is not completed successfully and the time-controlled cycle is launched

The ❄️, ❄️❄️ and 🕒 icons remain steady

The display shows the remaining time of the cycle



Press  or  to change the value

Use the  and  keys to change the value

DEFROSTING





Press  for 4 seconds to run the defrosting cycle

The ❄️ icon is on, blinking during dripping

CHANGING PARAMETERS

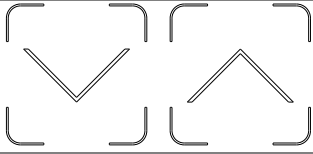
ATTENZIONE: nel caso di utilizzo in utenza di questa funzione, contattare il costruttore.



Press the  and  keys for 4 seconds to gain access to the mode for programming parameters

The display shows **"PA"**



Press the  key to gain access to service parameters

The display shows the value **"0"**

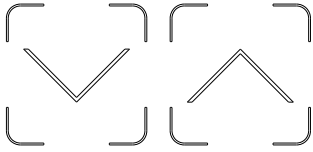



Press  within 15 seconds to set the password **"-19"**



Press  or do not operate 15 sec

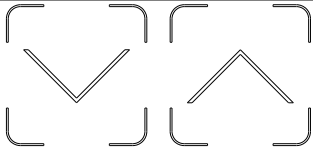

The display shows **"PA"**

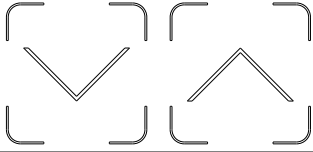

Press the  and  keys for 4 seconds

The display shows **"CA1"**





Use the  and  to select a parameter

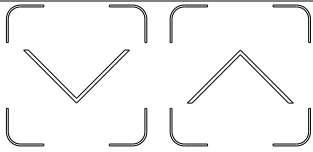

Press  to display the value of the parameter





Press  and  within 15 seconds to change the value of the parameter

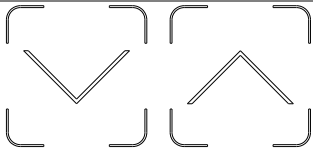

Press  or do not operate for 15 seconds to confirm the new value



Press  and  for 4 seconds or do not operate for 60 seconds to exit the procedure

ALARMS AND FAULT ANALYSIS

If the fault is not corrected by following the above instructions ask for skilled assistance and avoid carrying out any other operations, especially on the electricals. When informing the servicing company of the fault, state 1 and 5 numbers.

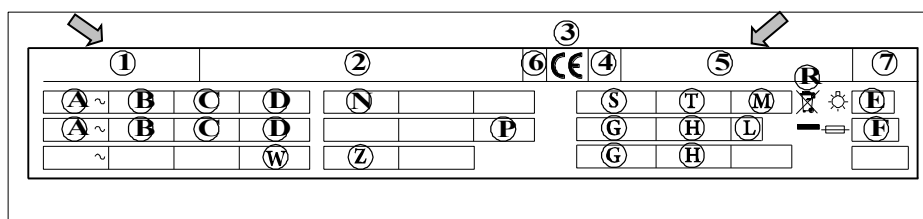

SIGNALS

LED	MEANING
	<p>Positive quick cooling led <i>if it is lit</i>, positive blast chilling in progress <i>if it flashes</i>, you have selected a positive blast chilling and preservation cycle</p>
	<p>Negative quick cooling led <i>if it is lit</i>, negative blast chilling in progress <i>if it flashes</i>, you have selected a negative blast chilling and preservation cycle</p>
HARD	<p>Hard quick cooling led <i>if it is lit</i>, hard chilling in progress <i>if it flashes</i>, you have selected a hard chilling and preservation cycle</p>
	<p>Blast chilling with probe LED <i>if it is lit</i>: • blast chilling with probe in progress <i>if it flashes</i>: • the test to verify the insertion of the probe was not completed successfully • you have selected a blast chill and preservation cycle with probe</p>
	<p>Time-controlled blast chill LED <i>if it is lit</i>: • timed blast chilling in progress <i>if it flashes</i>: • day and time setting in progress • you have selected a timed blast chill and preservation cycle</p>
	<p>Storing LED <i>if it is lit</i>, preservation in progress <i>if it flashes</i>, the compartment probe is displayed during the cycle</p>

**Defrost LED**

if it is lit, the defrost will be running

if it flashes, the dripping will be running

**Pre-cooling LED**

if it is lit, pre-cooling in progress and cell temperature has reached the one set with parameter r12

if it flashes, pre-cooling in progress and cell temperature has not reached the one set with parameter r12

**LED on/off**

if it is lit, equipment in “standby”

if it is off, equipment in “on”

**LED Celsius degree**

if it is lit, the unit of measure of the temperatures will be Celsius degree

**LED Fahrenheit degree**

if it is lit, the unit of measure of the temperatures will be Fahrenheit degree

min**LED minuti**

if it is lit, time is measured in minutes

INDICATIONS**CODE****MEANING****Loc**

The keyboard is locked

UnL

The keyboard is unlocked

ALARMS**CODE****MEANING****AL****Lower temperature alarm***Remedies:*

- check the cabinet temperature
- look at parameters A1 and A2

Effects:

- no effect

AH**Upper temperature alarm***Remedies:*

- check the cabinet temperature
- look at parameters A4 and A5

Effects:

- the instrument will store the alarm

id **Open door alarm**
Remedies:

- verify the state of the door
- look at parameters i0 and i1

Effects:

- effect determined by the parameter i0

HP **High pressure alarm**
Remedies:

- verify the high pressure inlet conditions
- look at parameters i5 and i6

Effects:

- effect determined by the parameter i5

ERRORS

CODE	MEANING
------	---------

Pr1 **Cabinet probe error**
Remedies:

- look at parameter P0
- check the integrity of the probe
- check the connection instrument-probe
- check the cabinet temperature

Effects:

- equipment in “standby”; no cycle can be selected or started
- during blast chilling, the cycle is interrupted
- during preservation, the compressor activity depends on parameters C4 and C5 or C9
- defrosting is never activated
- the heating elements of the door do not turn on
- the “AL” minimum temperature alarm is never activated
- the “AH” maximum temperature alarm is never activated

Pr2 **Needle Probe Error**
Remedies:

- look at parameter P0
- check the integrity of the probe
- check the connection instrument-probe
- check the cabinet temperature

Effects:

- equipment in “standby”; the blast chill cycles with probe are timed
- during positive blast chilling with probe, the duration of the cycle is established by parameter r1
- during negative blast chilling with probe, the duration of the cycle is established by parameter r2
- heating is interrupted while heating the needle probe

Pr3 **Evaporator probe error**
Remedies:

- look at parameter P0
- check the integrity of the probe
- check the connection instrument-probe
- check the cabinet temperature

Effects:

- if parameter P4 has value 1, the defrost will last the time you will have set with parameter d3
- if parameter F0 is set to 1, parameter F16 has no effect
- if parameter F4 is set to 1, the equipment works as if the parameter were set to 2

MAINTENANCE



WARNING

Refer to the chapter “Safety warnings and information”

ROUTINE MAINTENANCE

The following care operations must be carried out by an operator.



IMPORTANT

Problems resulting from a lack of care as described below will not be covered by the warranty.



WARNING

Before any operation, disconnect the equipment from the electrical mains.

It is advisable to clean the internal cabinet weekly or when the equipment is idle for more than 12 hours; increase the frequency of cleaning according to use of the equipment.

Cleaning the interior and accessories

Before use, clean all internal parts and accessories with lukewarm water and neutral soap or with products that are more than 90% biodegradable (to reduce the emission of pollutants into the environment), then rinse and dry thoroughly.

The conformation of the cabinet and the design of the internal components allow all parts to be washed and cleaned accordingly.

CAUTION



DO NOT USE STEEL WOOL OR SIMILAR MATERIAL TO CLEAN STAINLESS SURFACES.

DO NOT USE CHLORINE, SOLVENT-BASED CLEANING AGENTS (SUCH AS TRICHLOROETHYLENE ETC.) OR ABRASIVE POWDERS.



NEEDLE PROBE CLEANING



IMPORTANT

Take particular care uses the needle probe, bearing in mind that it is a sharp object that must be handled with particular care when cleaning.

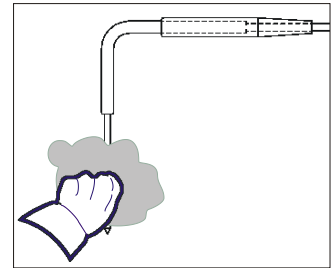

We recommend cleaning the needle probe periodically to ensure its optimal operation. The probe should be cleaned manually using lukewarm water and mild soap, then rinsed with clean water and disinfectant solution.



CAUTION

Never clean the probe with boiling water.



TRAY HOLDERS AND INNER STRUCTURE

The tray holders and inner structure are removable and dishwasher-safe.

Proceed as shown in the figure below to remove them.



DRAIN PLUG

During cooking cycles, remove the cap to drain the water on the internal bottom of the chamber.

To clean the drain plug, remove it as shown in the figure.



Clean it with lukewarm water and mild soap, then rinse and dry thoroughly.

OTHER SURFACES

Clean plastic and metal parts only with non-aggressive cleaning agents. Stop using these products immediately if you detect any visual or tactile changes to the surfaces and rinse with water (e.g. discolouration plastic/fusion/other, or rust marks/scratches on metal). Dry carefully after rinsing.

Do not aim jets of water directly at the unit to clean it, especially avoid the use of pressure lances.

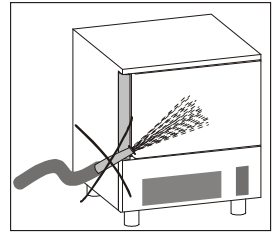

Do not rinse with sharp or abrasive tools, especially the evaporator.

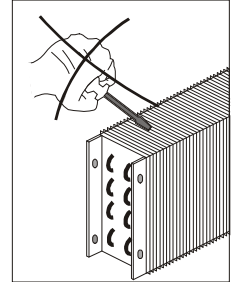

You may clean inside the evaporator after loosening the knobs and rotating the protection component.

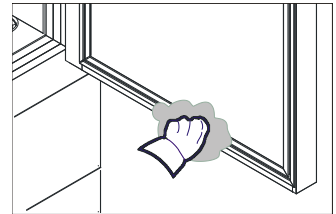

Wash the door gasket with water. Accurately dry with a dry cloth. We recommend wearing protecting gloves throughout the operations.

CLEANING THE AIR CONDENSER

The air condenser should be kept clean to ensure the appliance's performance and efficiency, as air should freely circulate inside the appliance.

The condenser should therefore be cleaned every 30 days, using non-metal brushes to remove all dust and dirt from condenser blades.

Access to the condenser is from the front.
Unhook the front guard, pulling it towards you.

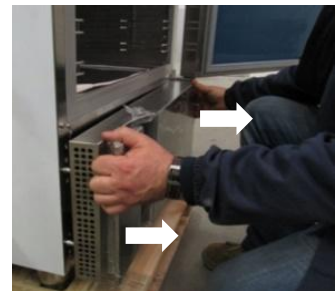

In the mod. ... 102 the condensing system is positioned in the upper part of the appliance.

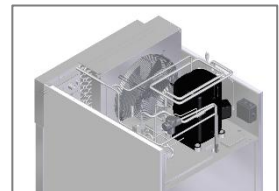

STAINLESS-STEEL MAINTENANCE

By stainless steel we mean INOX AISI 304 steel.
 We recommend following the instructions below for the maintenance and cleaning of stainless-steel parts.
 This is of the utmost importance to ensure the non-toxicity and complete hygiene of the processed foodstuffs.
 Stainless-steel is provided with a thin oxide layer which prevents it from rusting. However, some detergents may destroy or affect this layer, therefore causing corrosion.
 Before using any cleansing product, ask your dealer about a neutral chloriness cleansing product, as to avoid steel corrosions.
 If the surface has been scratched polish it with fine STAINLESS-STEEL wool or a synthetic-fibre abrasive sponge. Always rub in the direction of the silking.



PRECAUTIONS IN THE CASE OF LONG PERIODS OF INACTIVITY

Observe the following precautions during long periods of inactivity:

- Disconnect the power supply;
- Remove all food from the cabinet and/or drawers and clean the interior and accessories;
- Clean the cabinet vigorously and all stainless steel surfaces using a cloth slightly soaked in Vaseline oil, so as to spread a protective film;
- Leave the door open to facilitate air circulation to prevent the formation of unpleasant odours;
- Cover the compressor unit with a nylon cloth to protect it from dust;
- Air the premises out periodically.

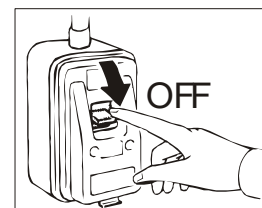

After maintenance work is completed, it must be ensured that the machine is able to work safely, and in particular that the protective and safety devices are fully functional.

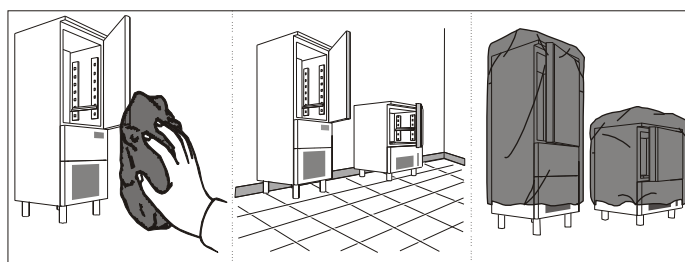

TROUBLESHOOTING

ANOMALY TABLES

The equipment always displays a warning message or an alarm in the event of an anomaly. Type on the warning icon to view the status of the outputs/inputs to display the alarm. The warning remains active until the problem is resolved.



Warning icon

Follow the instructions provided by the equipment and contact Customer Service if required, remembering to:

- Disconnect the equipment from the electrical system;
- Deactivate the protection switch upstream of the equipment;

The controller records 40 alarm events. The events are recorded in the list in the Settings menu (Alarm History).

In some cases, faults can be resolved quickly and easily by following the instructions in the following troubleshooting guide:

Type of anomaly	Description	Possible Causes	Actions
RTC	Low battery level.	<ul style="list-style-type: none"> • Control interface battery is flat. • Circuit board fault. 	Problem with the internal clock battery. Clock functions will not work correctly (e.g. HACCP event recording will be incorrect). CALL FOR SERVICE.
CABINET PROBE	Cabinet probe fault.	Probe connector disconnected from terminal. Probe and/or probe cable damaged or interrupted.	The blast-chiller will run until the end of the active cycle. No further cycle can be run until the probe is replaced by Technical Service. CALL SERVICE.
EVAPORATOR PROBE	Evaporator probe fault.	Probe connector disconnected from terminal. Probe and/or probe cable damaged or interrupted.	The blast-chiller works: the defrost setting is time-dependent. CALL SERVICE.
CONDENSER PROBE	Condenser probe fault.	Probe connector disconnected from terminal. Probe and/or probe cable damaged or interrupted.	CALL SERVICE. Fault locking an active cycle. Remove load from cabinet to avoid food waste.
NEEDLE SENSOR 1	Needle sensor 1 fault	Improper use of the needle probe (e.g. pinched or frayed wire). Connector fault. Probe fault. PCB fault.	Cycle running: <ul style="list-style-type: none"> • The cycle continues in probe mode until at least one of the 3 needle probe points is running. • The cycle switches to time mode if none of the 3 sensors are operating. During STANDBY phase: <ul style="list-style-type: none"> • The cycle can be started as long as at least one of the 3 points is active. • The cycle can be started in time mode if all points are faulty. • Call Service to restore full functionality. Replace probe. Replace board. Call Service to restore full functionality.
NEEDLE SENSOR 2	Needle sensor 2 fault	Improper use of the needle probe (e.g. pinched or frayed wire). Connector fault. Probe fault. PCB fault.	Cycle running: <ul style="list-style-type: none"> • The cycle continues in probe mode until at least one of the 3 needle probe points is running. • The cycle switches to time mode if none of the 3 sensors are operating.

			<p>During STANDBY phase:</p> <ul style="list-style-type: none"> • The cycle can be started as long as at least one of the 3 points is active. • The cycle can be started in time mode if all points are faulty. <p>Replace probe. Replace board. Call Service to restore full functionality.</p>
NEEDLE SENSOR 3	Needle sensor 3 fault	<p>Improper use of the needle probe (e.g. pinched or frayed wire). Connector fault. Probe fault. PCB fault.</p>	<p>Cycle running:</p> <ul style="list-style-type: none"> • The cycle continues in probe mode until at least one of the 3 needle probe points is running. • The cycle switches to time mode if none of the 3 sensors are operating. <p>During STANDBY phase:</p> <ul style="list-style-type: none"> • The cycle can be started as long as at least one of the 3 points is active. • The cycle can be started in time mode if all points are faulty. <p>Replace probe. Replace board. Call Service to restore full functionality.</p>
THERMAL SWITCH	Compressor thermal switch tripped.	<p>Compressor overload. Inadequate power supply. (connector disconnected). Damaged compressor.</p>	<p>The blast-chiller is locked and only the condenser fan remains in operation. Check for any obstructions in the condensing coil. CALL CUSTOMER SERVICE.</p>
HIGH PRESSURE	Safety pressure switch tripped.	<p>The working ambient temperature is too high. The condenser fan does not work. The food load exceeds the suggested values. Condensing coil clogged with dust.</p>	<p>Reposition the machine to ensure proper ventilation. The blast-chiller is locked and only the condenser fan remains in operation. Check the connections of the fan and/or run condenser if present. Check for any obstructions in the condensing coil. Clean the condensing coil. CALL CUSTOMER SERVICE.</p>
LOW PRESSURE	Safety pressure switch intervention.	<p>Refrigerant leak resulting in insufficient charge. Evaporator fan not working. Solenoid valve locked. Evaporator coil with ice</p>	<p>The blast-chiller is locked and only the condenser fan remains in operation. Check solenoid valve functionality. Defrost. Check fan connections. CALL CUSTOMER SERVICE.</p>
DOOR OPEN	Door open Stop cycle.	<p>The door stays open beyond the permitted limit. Faulty or interrupted closing device (micromagnetic).</p>	<p>Make sure that the machine door is closed and that any physical obstructions are not preventing the door from closing. Check micro connections. If the alarm remains active call Service.</p>
HIGH TEMPERATURE	High cabinet temperature	<p>Door open. Food in the cold cabinet is too hot. Check the cabinet probe. Refrigerant leak. Ice or frost on evaporator.</p>	<p>Cabinet temperature has exceeded the set limit in addition to the signal delay. Cycle in continuous operation. Check parameter A4. Perform defrost cycle. Check the condition of the gasket. Check the cabinet temperature with an external thermometer. If the alarm persists even when the cabinet temperature is low, call Service.</p>
LOW TEMPERATURE	Low cabinet temperature (only for positive or negative holding cycles)	<p>Low set delay time. Set temperature difference too small. Evaporator frozen. Evaporator fan not working. Compressor always ON. Non-compliant temperature probe</p>	<p>The cabinet temperature is below the cycle temperature setpoint minus the differential. The cycle will continue until it stops. Open the door to raise the temperature inside the cabinet and check after about 3 minutes. Start a manual defrost cycle. Check compressor relay or contactor.</p>

			Check internal temperature with reference thermometer Check parameter A1. If the problem persists, call Service.
CYCLE DURATION	Cycle time over the permitted limit	Food load in cabinet too high. Food too thick. Food temperature too high. Evaporator fan fault. Refrigerant leak.	The core temperature has not reached the setpoint within the set time period. Reduce thermal load. Reduce food thickness.
BOARD COMMUNICATION	Power board communication error	Internal error – circuit board disconnected – Circuit board fault.	Check whether the problem persists when ON/OFF is operated. If problem persists, call Service.
BOARD COMPATIBILITY	Corrupted stored parameters	Software corruption	Check whether the problem persists when ON/OFF is operated. If problem persists, call Service.
NEEDLE	Fault on all sensors.	Improper use of the needle probe (e.g. pinched or frayed wire). Connector fault. Probe fault. PCB fault.	Cycle running: <ul style="list-style-type: none"> The cycle continues in probe mode until at least one of the 3 needle probe points is running. The cycle switches to time mode if none of the 3 sensors are operating. During STANDBY phase: <ul style="list-style-type: none"> The cycle can be started as long as at least one of the 3 points is active. The cycle can be started in time mode if all points are faulty Call Service to restore full functionality.
POWER FAILURE	Supply power absent.	No power. Power system failure. Other electrical problems (e.g. power loss). Damaged power cable. Fuse tripped.	The machine restarts, signalling intervention of the alarm. The cycle restarts automatically as soon as power is restored. The machine has not been used for a period of time: check the start and end time of the cycle. Check the plug or the general electrical control panel. Check for shorts or overload. If the alarm persists, call Service.
SANITATION PROBE INSERTION	NA	NA	NA
SANITATION DURATION	NA	NA	NA
CONDENSER OVERHEAT	High cabinet temperature	Incorrect condenser probe position. Fan condenser not working. The condenser is dirty or the ventilation grille has clogged holes. The machine cannot dissipate heat from the motor unit. Refrigerant leakage (compressor always ON).	This fault locks the active cycle: Remove load from cabinet to avoid food waste. Use a Hoover and remove any dirt/dust residue from the ventilation grille. If the alarm persists, call Service.
COMPRESSOR LOCKED	High cabinet temperature	Incorrect condenser probe position. Fan condenser not working. The condenser is dirty or the ventilation grille has clogged holes. The machine cannot dissipate heat from the motor unit. Refrigerant leakage (compressor always ON). Thermal relay tripped. Check parameters C7 and C8.	This fault locks the active cycle: Remove load from cabinet to avoid food waste. Use a Hoover and remove any dirt/dust residue from the ventilation grille. If the alarm persists, call Service.
NEEDLE PROBE INSERTION	Needle probe not inserted.	No needle probe insertion.	Check correct insertion of the needle probe. Reactivate the cycle and, if the problem persists, call Service.

HUMIDITY	Humidity probe fault.	Probe connector disconnected from terminal. Probe and/or probe cable damaged or interrupted.	CALL SERVICE. Fault locking an active cycle.
H2O INJECTION MAINTENANCE	Atomiser nozzle cleaning	The number of humidification cycles has exceeded the set limits depending on water hardness and temperature.	Call Service.
EXP COMMUNICATIONS	Expansion board communication error	Internal error – circuit board disconnected – Circuit board fault.	Check whether the problem persists when ON/OFF is operated. If problem persists, call Service.
EXP COMPATIBILITY	Corrupted stored parameters	Software corruption	Check whether the problem persists when ON/OFF is operated. If problem persists, call Service.
The display is switched off (OFF) while the main switch is on.		Display connector disconnected.	Switch the unit On/Off. If the problem persists, call Service.
The display is locked and does not react.		No power supply. Shorted fuses. Faulty electrical contacts. Problems with the software.	Switch the unit On/Off. If the problem persists, call Service.
The display has condensation on the inside.		Water infiltration during cleaning.	No action required if the unit can continue to operate. If a malfunction occurs, call Service.
External noise/vibration with cycle ON.		Unit not level. Water collection tray located underneath the motor vibrating. Condenser panel not secured.	Level the machine by operating the adjustable feet. Remove the water in the tray and adjust the support guides. Secure the condenser panel. If the problem persists, call Service.
Internal noise/vibration with cycle ON.		Tray holders are not aligned. Internal fan obstruction. Evaporator fan/casing deflector not properly secured.	Check that the right/left holders are properly levelled. Check that the cabinet fan is working properly without obstructions. Check that the casing is properly secured with the knobs. If the problem persists, call Service.
The machine takes too long to reach the desired temperature.		High food load. Refrigerant leakage. Condensing coil clogged with dust. Solenoid valve fault. Cabinet fan is not connected correctly. Thermostatic valve needs adjustment. Heating element relay is locked. Thermal insulation of piping Damaged Evaporator loaded with frost. Unsuitable door closure.	Reduce the food load in the cell. Clean the condensing coil. Defrost. If the problem persists, call Service.
Compressor fault		The compressor does not start. Compressor oscillates intermittently or discontinuously. Compressor thermal relay tripped. Compressor noisy. Clicson tripped. Contactor failure.	CALL SERVICE.
Failed defrost.		Check defrost parameters. Check defrost solenoid valve operation. Check that the defrost probe is reading correctly. Check heating element operation. Defrost program set with inappropriate parameters. Faulty bimetallic thermostat.	Check the defrost cycle setting (see operation and maintenance manual). Check bimetallic thermostat operation. Check evaporator heating element operation.

Evaporator fans not working.	Safety micro fault. Failure on run condenser (capacitor) of the fan. Faulty or short-circuited fan. Check electrical connections.	Check magnetic micro operation. Check the status of the fan condenser in the electrical panel. Check fan operation and replace if necessary.
Condenser fans not working.	Compressor not working. Fan capacitor failure Switch tripped – fans ON Faulty or short-circuited fan.	Check compressor operation. Check the status of the fan condenser in the electrical panel. Check whether the pressure switch has tripped. Check fan operation and replace if necessary.
Door does not close properly.	Worn gasket. Door misalignment.	Replace gasket. Check the correct (current draw) and surface temperature of the door resistance. Adjust door brackets.

(tab 11)

Once the above checks have been carried out, if the defect persists, contact Customer Service, remembering to indicate:

- The nature of the defect
- The machine code (1)
- The serial number (5)

①				②		③	④	⑤		⑥	⑦
A ~	B	C	D	N		CE	S	T	M	⚙️	E
A ~	B	C	D			P	G	H	L	⎓	F
~			W	Z			G	H			

EXTRAORDINARY MAINTENANCE

The information and instructions in this section are reserved for specialised personnel, authorised to operate on the equipment components.

MAINTENANCE OF PANEL BOARD

Turn the mains switch OFF.
Disconnect the plug.

To be able to access the electric picture:

Mod. ...51...

Unhook the front guard, pulling it towards you.

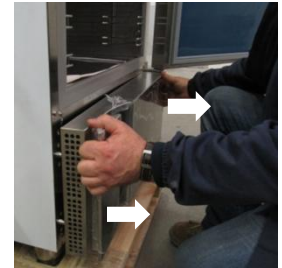

Remove the closing panel screws.
Remove the closing panel.



Remove the electrical panel locking screw.

Move the electrical panel box along the slide.



Mod. ...51H

Remove the side panels by means of the screws.

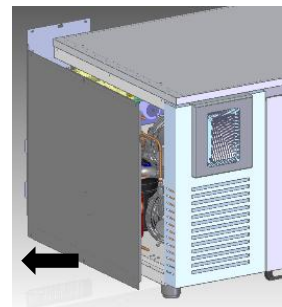

Mod. ...101L -...141L-...171L

Remove the protection panel out in the upper part of the appliance.

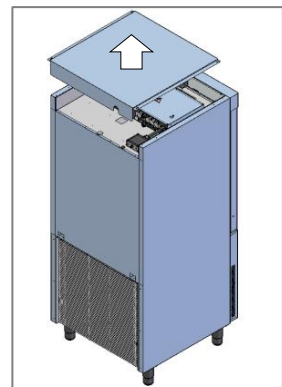

Mod. ...102

Rotate the dashboard on the side heads by removing the screw under the dashboard.

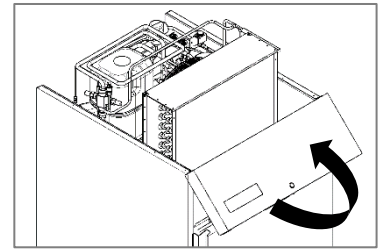

CONDENSING SYSTEM MAINTENANCE

Mod. ...51... - ...101L - ...141L - ...171L

To access the condensing system, remove the rear protective grille, undoing the screws.



Mod. ...51H

To access the condensing system, remove the side panel, undoing the screws.



Mod. ...102

The condensing system is positioned in the upper part of the appliance.

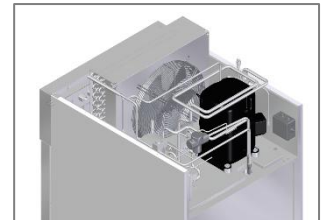

FURTHER INFORMATION

ERGONOMIC FEATURES

CERTIFICATION

The ergonomic characteristics of the product, which can influence the physical and cognitive interaction the user has with it, have been assessed and certified.

In fact, a product with ergonomic features meets specific ergonomic requirements belonging to three different areas:

polytechnical, biomedical and psychosocial (usability and satisfaction).

Tests were carried out with real users for each of these areas. The product was then found to comply with the ergonomic acceptability criteria set out in the standard.

GENERAL RECOMMENDATIONS

The blast-chiller has been designed and tested to minimise physical problems associated with product interaction.

Loading and unloading trays and interacting with the product can lead to incorrect postures and the handling of heavy weights, areas of your daily activity that we have tried to alleviate.

In any case, we would like to suggest some operational procedures to adopt:

- Handle the tray in a balanced manner, trying not to bend your back when loading/unloading.
- If possible, bend your legs and do not bend your back forward when placing the trays in the lower shelves and while trying to reach tools or objects placed below.
- Whenever possible, try to position the trays in the cabinets with their weight in mind, as suggested by the attached images.
- If possible, push and pull the tray trolley to reduce distances.
- Maintaining viewing distance to understand the information shown on the display or to view the object in the cabinet, reducing the time spent with eyes facing upwards (neck extension) as much as possible.

RECOMMENDED HANDLING OF TRAYS ACCORDING TO THEIR WEIGHT

Try to position the trays in the cabinets with their weight as suggested by the images below.

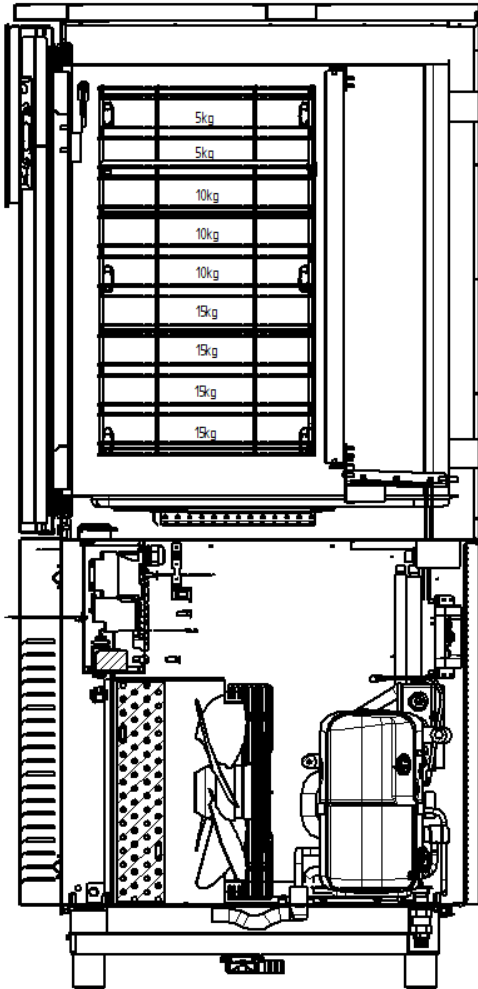
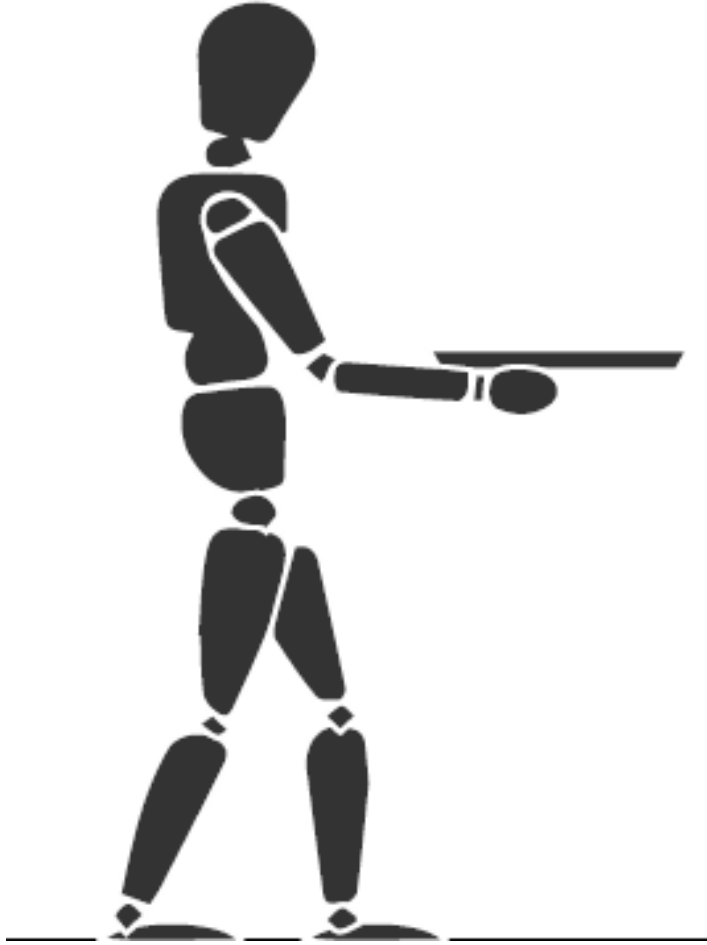
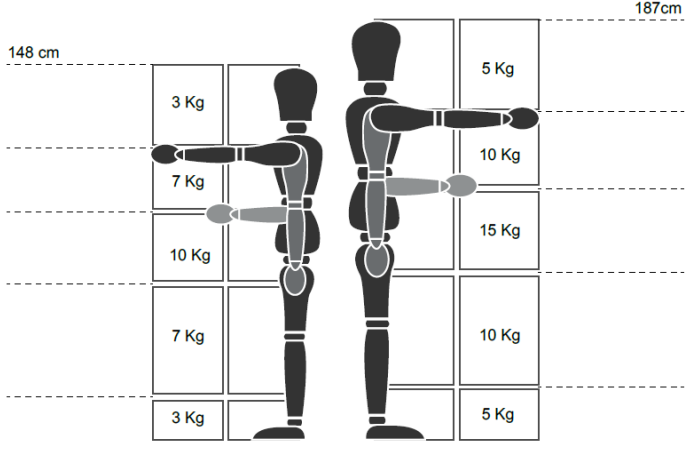

ENERGY CONSUMPTION CHART (*)

Modello - Model	..51H	..51DM	..51 ..51M ..S51M	..101L ..S101L	JF141L JFS171L HPC171L	HPC51M	HPC101L	HPC102		
Tipo di prodotto – Type of product	Abbattitore/surgelatore Blast chiller and freezer									
Refrigerating fluid	R290									
GWP	3									
Refrigerant load [kg]	0,1	0,07	0,08	0,15+0,15	0,15+0,15	0,15	0,15+0,15	0,15+0,15		
Program used for the blast-chilling process	Hard Blast-chilling									
Program used for the freezing process	Hard Freezing									
Description	Symbol	Value							Unit	
Blast-chilling energy consumption	E	0,08	0,07	0,08	0,08	0,08	0,08	0,08	0,08	[kWh/kg]
Blast-chilling cycle mass		15	18	20	45	70	25	60	70	[kg]
Freezing energy consumption	E	0,3	0,27	0,26	0,28	0,25	0,26	0,25	0,26	[kWh/kg]
Freezing cycle mass		7	10	12	28	38	15	30	38	[kg]
Refrigerant load		30	30	30	30	30	30	30	30	[°C]
Ambient operating temperature	t	120							min	
Blast-chilling cycle from 65°C to +10°C	t	270							min	
Contact details	Angelo PO Grandi Cucine spa a sole-shareholder company									

(tab 12)

(*) EN ISO 22042:2021

WIRING DIAGRAM PLATE

The electrical diagram is shown on the last page of the booklet.

N°	DESCRIPTION	N°	DESCRIPTION
1	COMPRESSOR	73	FUSE-HOLDER WITH UNIPOLAR FUSE
1A	COMPRESSOR	75	ELECTROVALVE
2	CONDENSER FAN	75A	ELECTROVALVE
2A	THERMOSTATED CONDENSER FAN	76	MAGNETIC MICRO-SWITCH
3	GENERAL TERMINAL BOARD	77	COMPARTMENT PROBE
3A	GENERAL TERMINAL BOARD	78	EVAP./DEFROST PROBE
3B	GENERAL TERMINAL BOARD	79	NEEDLE CORE PROBE
9	EVAPORATOR FUN	79A	MULTIPOINT NEEDLE CORE PROBE
9A	EVAPORATOR FUN	79B	MULTIPOINT PROBE RESISTANCE
9B	EVAPORATOR FUN	80	PTC RESISTANCE FOR COMPRESSOR CASING
20	DOOR ANTICONDENSING RESISTOR	86	CONDENSER PROBE
21	DEFROST RESISTANCE	87	LCD QUICK COOLER CARD
21A	DEFROST RESISTANCE	97A	EVAP. FAN CHOKE MODULE
25	TRANSFORMER	102	BIMETALLIC SAFETY THERMOSTAT
44	RELAY COMPRESSOR	120	ELECTRICAL BOX MOTHERBOARD
65	CONTACTOR	122	LED LAMPS
66	THERMAL RELAY	127	RGB CONTROLLER
67	EVAPORATOR FAN RUN CAPACITOR	128	USB ADAPTER
67A	EVAPORATOR FAN RUN CAPACITOR	129	ENCODER ADAPTER
69	GROUNDING TERMINAL	132	LED DISPLAY ELECTRONIC BOARD
70	HIGH PRESSURE PRESSOSTAT	135	USER INTERFACE WITH LED DISPLAY
70A	HIGH PRESSURE PRESSOSTAT	140	LIQUID SOLENOID VALVE EMI FILTER
70B	CONDENSATION PRESSURE SWITCH	140A	LIQUID SOLENOID VALVE EMI FILTER
70C	CONDENSATION PRESSURE SWITCH	144	INDUCTIVE FAN FILTER (CHOKE)
71	POWER PANEL ELECTRONIC CARD	144A	INDUCTIVE FAN FILTER (CHOKE)
72	ELECTRONIC DATA CARD LCD		

IT - È vietata la riproduzione, anche parziale, di questo documento senza il consenso del fabbricante. Egli è impegnato in una politica di continuo miglioramento e si riserva il diritto di modificare questa documentazione senza l'obbligo di preavviso purché ciò non costituisca rischi per la sicurezza.

GB - Even partial reproduction of this document without the constructor's consent is forbidden. The constructor is committed to a policy of continuous improvement, and reserves the right to update this documentation without notice provided this does not involve safety risks.

DE - Die vollständige oder teilweise Reproduktion dieses Dokuments ohne die Zustimmung des Herstellers ist verboten. Der Hersteller behält sich im Rahmen seiner Politik der kontinuierlichen Verbesserung das Recht zu Änderungen an dieser Dokumentation vor, ohne zu einer Benachrichtigung verpflichtet zu sein, sofern hierdurch die Sicherheit nicht beeinträchtigt wird.

FR - La reproduction, même partielle, de ce document est interdite sans le consentement du constructeur. Dans le but d'améliorer son produit, le constructeur se réserve le droit de modifier cette documentation, sans préavis, pourvu que cela ne constitue pas de risques pour la sécurité.

ES - Está prohibida la reproducción, incluso parcial, del presente documento sin la autorización expresa del constructor. El constructor, en la óptica de mejorar continuamente sus productos, se reserva el derecho a modificar esta documentación sin que por ello esté obligado a dar previo aviso y siempre que las modificaciones no representen una fuente de potencial peligro para la seguridad del usuario.

